

# STANDARD PRACTICES FOR PESTICIDE APPLICATORS

**WORK SAFE BC**

WORKING TO MAKE A DIFFERENCE  
[worksafebc.com](http://worksafebc.com)





## **About WorkSafeBC**

WorkSafeBC (the Workers' Compensation Board) is an independent provincial statutory agency governed by a Board of Directors. It is funded by insurance premiums paid by registered employers and by investment returns. In administering the *Workers Compensation Act*, WorkSafeBC remains separate and distinct from government; however, it is accountable to the public through government in its role of protecting and maintaining the overall well-being of the workers' compensation system.

WorkSafeBC was born out of a compromise between B.C.'s workers and employers in 1917 where workers gave up the right to sue their employers or fellow workers for injuries on the job in return for a no-fault insurance program fully paid for by employers. WorkSafeBC is committed to a safe and healthy workplace, and to providing return-to-work rehabilitation and legislated compensation benefits to workers injured as a result of their employment.

## **WorkSafeBC Prevention Information Line**

The WorkSafeBC Prevention Information Line can answer your questions about workplace health and safety, worker and employer responsibilities, and reporting a workplace accident or incident. The Prevention Information Line accepts anonymous calls.

Phone 604 276-3100 in the Lower Mainland, or call 1 888 621-7233 (621-SAFE) toll-free in British Columbia.

To report after-hours and weekend accidents and emergencies, call 604 273-7711 in the Lower Mainland, or call 1 866 922-4357 (WCB-HELP) toll-free in British Columbia.





# STANDARD PRACTICES FOR PESTICIDE APPLICATORS



WORKING TO MAKE A DIFFERENCE  
[worksafebc.com](http://worksafebc.com)



# WorkSafeBC Publications

---

Many publications are available on the WorkSafeBC web site. The Occupational Health and Safety Regulation and associated policies and guidelines, as well as excerpts and summaries of the *Workers Compensation Act*, are also available on the web site: [WorkSafeBC.com](http://WorkSafeBC.com)

Some publications are also available for purchase in print:

Phone: 604 232-9704

Toll-free phone: 1 866 319-9704

Fax: 604 232-9703

Toll-free fax: 1 888 232-9714

Online ordering: [WorkSafeBC.com](http://WorkSafeBC.com) and click on Publications; follow the links for ordering

© 1985, 1990, 2009 Workers' Compensation Board of British Columbia. All rights reserved. The Workers' Compensation Board of B.C. encourages the copying, reproduction, and distribution of this document to promote health and safety in the workplace, provided that the Workers' Compensation Board of B.C. is acknowledged. However, no part of this publication may be copied, reproduced, or distributed for profit or other commercial enterprise, nor may any part be incorporated into any other publication, without written permission of the Workers' Compensation Board of B.C.

## Library and Archives Canada Cataloguing in Publication

Standard practices for pesticide applicators : a manual of health information and safe practices for workers who apply pesticides / WorkSafeBC. -- 2009 ed.

ISBN 978-0-7726-6210-1

1. Pesticides--Safety measures. 2. Pesticides--Application--Safety measures.  
I. WorkSafeBC II. Title: Manual of health information and safe practices for workers who apply pesticides.

SB952.5.S72 2009

363.17'92

C2009-906717-X

Cover photo © iStockphoto/alohaspirit.

---



## Acknowledgments

---

WorkSafeBC would like to thank everyone who contributed their time and expertise to the development of this document, including Rex Eaton and the Farm and Ranch Safety and Health Association (FARSHA).





Standard Practices for Pesticide Applicators

- iv -





# Contents

---

<b>1. Introduction.....</b>	<b>1</b>
How to use this manual.....	3
Pests and pesticides.....	4
Worker health and safety .....	5
Pesticide legislation .....	6
<b>2. Sources of pesticide information .....</b>	<b>9</b>
Introduction.....	11
Labels.....	12
Material safety data sheets (MSDSs).....	18
Worker education and training.....	24
<b>3. Types of pesticides .....</b>	<b>25</b>
Introduction.....	27
Classifying by target organism .....	28
Classifying by formulation.....	29
Classifying by chemical family .....	31
<b>4. Routes of entry and health effects.....</b>	<b>33</b>
Routes of entry—how pesticides enter the body.....	35
Health effects.....	38
<b>5. Pesticide hazard evaluation .....</b>	<b>53</b>
Introduction.....	55
Pesticide toxicity .....	57
Amount of pesticide .....	58
Pesticide formulation.....	59
Amount of pesticide in the air.....	61
Warning properties .....	65
Persistence .....	67
Mixing, loading, and application equipment .....	72
<b>6. General precautions when working with pesticides .....</b>	<b>85</b>
Introduction.....	87
The pesticide safety program .....	88
Personal protective equipment.....	92
Transport of pesticides .....	110
Pesticide storage .....	111





---

Mixing and loading procedures.....	119
Cross-connection control.....	120
Application procedures .....	125
Disposal of pesticides and containers .....	127
Personal cleanliness and wash-up facilities .....	128
<b>7. Precautions for specific pesticide applications.....</b>	<b>131</b>
Introduction.....	133
Field and orchard application.....	134
Landscape application .....	137
Silviculture application.....	140
Aerial application .....	144
Structural pesticide application.....	148
Fumigation.....	153
Wood treatment.....	162
<b>8. Protecting re-entry workers .....</b>	<b>167</b>
Introduction.....	169
Warning signs.....	170
Restricted entry intervals .....	173
Entry procedures .....	174
Exceptions.....	175
<b>9. Emergency procedures.....</b>	<b>177</b>
Introduction.....	179
Poisoning .....	180
Fires .....	185
Pesticide spills .....	187
<b>10. Maintenance and calibration of application equipment .....</b>	<b>189</b>
The maintenance program .....	191
Equipment calibration .....	196
<b>Emergency telephone numbers.....</b>	<b>202</b>

---







# Introduction

**This chapter includes the following sections:**

- How to use this manual
- Pests and pesticides
- Worker health and safety
- Pesticide legislation







## How to use this manual

---

This manual deals with the health and safety of workers who work with or near pesticides. It is meant for all industries, including

- Agriculture
- Silviculture
- Structural pest control
- Wood treatment
- Aerial application
- Landscaping

The manual also focuses on the health and safety of

- Workers who re-enter treated areas or who handle treated materials
- Emergency response teams that deal with pesticide spills or fires
- First aid personnel and medical staff who deal with poisonings

The manual has ten chapters. The first five provide basic information upon which to build a pesticide safety program. Topics covered include sources of information on pesticides, classification of pesticides, toxic effects, and equipment hazards.

The last five chapters deal with implementation of a pesticide safety program, including

- Choice of hazard controls
- Selection of personal protective equipment
- Transport and storage of pesticides
- Safe mixing, loading, and application practices
- Site re-entry, emergency, and maintenance procedures

This manual may be used jointly with documents such as the

- *Handbook for Pesticide Applicators and Dispensers* (B.C. Ministry of Environment), which provides information on pesticide selection and environmental precautions
- B.C. crop production guides (Ministry of Agriculture and Lands)
- *Forest Pesticide Handbook of British Columbia* (Ministry of Forests and Range)

For farmers and ranchers, *Standard Practices for Pesticide Applicators* should be considered a companion to other WorkSafeBC publications on health and safety in agriculture.



## Pests and pesticides

---

A *pest* is a troublesome or destructive animal, insect, plant, or mold. A *pesticide* is a product used to kill or control pests. There are about 6,000 different brands of pesticides in Canada. In some cases, *biological controls* such as insects, bacteria, and viruses are alternatives to chemical pesticides.

Because pesticides are designed to harm living organisms, they can harm people as well as pests.

The safe use of pesticides is in everyone's interest. Whenever workers handle or work near pesticides, measures must be in place that address the hazards involved and protect worker health and safety.





## Worker health and safety

---

A review of compensation claims has shown that about half of all cases of occupational disease attributed to pesticides involved mixers and applicators. The rest of the cases involved other workers, such as emergency response personnel and those who re-entered buildings and fields after pesticides had been applied.

Safety must play a major role in every aspect of pesticide use, from the proper choice of pesticides to their transportation, storage, mixing, loading, application, and disposal. Safety is also a key concern during re-entry to treated areas, equipment maintenance, and emergency procedures. There is a right way and a wrong way of doing anything. **The right way is the safe way.**

There are a number of factors that contribute to a safe and healthy workplace, such as

- **Choice of pest-control method**

Increasingly, alternatives to pesticides are being developed for the control of pests. Pesticides may be part of an integrated pest management program that involves other methods such as biological and administrative controls. If a pesticide is to be used, it must be selected with worker safety in mind.
- **Information**

Thorough and reliable information is a key to working safely with pesticides. It is the basis for evaluating the hazards that workers face when working with pesticides. Pesticide labels and material safety data sheets provide important information. The Canadian Centre for Occupational Health and Safety and government agencies with responsibilities for pesticides can also provide helpful information.
- **Control measures**

Types of controls include substitution of less hazardous materials, engineering controls, administrative controls, and personal protective equipment. Control measures must be in place and matched to the level of hazard. Employers must ensure that regular inspections are carried out to help ensure controls are effective.
- **Emergency procedures**

Employers must ensure that emergency procedures are developed to handle emergencies such as poisonings, fires, and spills. And if an incident occurs, the employer must immediately undertake an investigation to prevent similar incidents in the future.
- **Training**

Employers must ensure that workers are educated in the hazards of pesticides and trained in safe work and emergency procedures.





# Pesticide legislation

---

This manual is designed as a workplace information supplement to the requirements of statutes and regulations that control the use of pesticides in B.C. The major pieces of applicable legislation are as follows:

## 1. Federal

### ***Pest Control Products Act (PCPA)***

The PCPA requires pesticides to be registered with the Pest Management Regulatory Agency (PMRA) of Health Canada before they can be imported, manufactured, sold, or used in Canada. If registered, a pesticide is assigned a PCP registration number. This number, along with permitted uses, must appear on the product label.

In 2006, the PCPA was updated to include provisions such as

- Additional protection for children and pregnant women
- Improved public access to evaluation reports on pesticides
- A requirement for the PMRA to re-evaluate pesticides on a 15-year cycle
- A requirement for suppliers to report sales data

### ***Food and Drugs Act***

Under this legislation, Health Canada sets maximum limits for pesticide residues in foods. Federal authorities may inspect food for residues and seize a crop if limits are exceeded.

### ***Fisheries Act and Migratory Birds Convention Act***

Under these pieces of legislation, pesticide users can be prosecuted if they are responsible for harming fish or migratory birds, or for contaminating their habitats.

## 2. Provincial

### ***Workers Compensation Act and Occupational Health and Safety Regulation***

These pieces of legislation are intended for the protection of workers. They govern the use of pesticides at worksites that come under the authority of WorkSafeBC.



---

The *Act* and the Regulation provide three levels of protection for workers:

- **Core requirements**

These address the responsibilities of employers, workers, supervisors, owners, and suppliers—including those who supply pesticides. In addition, the requirements address the obligation to establish joint occupational health and safety committees or worker representatives in some workplaces, as well as an occupational health and safety program.

- **General chemical and biological requirements**

These address all hazardous materials, including pesticides, and cover matters such as

- Information requirements
- Storage
- Occupational exposure limits
- Use of control measures
- Personal hygiene and washing facilities
- Emergency procedures

- **Pesticide-specific requirements**

These address issues specific to pesticides, including

- Qualifications and certification of mixers, loaders, and applicators
- Control of pesticide drift
- Warning signs
- Restricted entry intervals to protect workers who enter treated areas
- Health monitoring of workers where applicable

### ***Integrated Pest Management Act and Regulations***

Administered by the Ministry of Environment, these pieces of legislation cover

- Requirements for licensing of businesses
- Certification of salespeople and applicators
- Pesticide-use permit restrictions
- The obligation for some large projects to submit a pesticide-use notice

The legislation also includes requirements to apply integrated pest management techniques, including the use of non-chemical methods where appropriate. Storage and transport requirements address the obligation for signage and labels, and for practices that protect food intended for human and animal consumption.





---

### **3. Local**

A number of regional districts and municipalities in B.C. have bylaws on the selection and use of pesticides, and on the control of pests such as weeds, insects, and rodents. Pesticide use must conform with local as well as provincial and federal requirements. If in doubt about local requirements, check with the municipality or regional district.





# 2 Sources of pesticide information

**This chapter includes the following sections:**

- Introduction
- Labels
- Material safety data sheets (MSDSs)
- Worker education and training









## Introduction

---

Before using any pesticide, read and understand information on the health hazards of the product and how to use it safely.

At minimum, an information system has three parts:

- **Labels** on containers that provide basic indicators of the level of hazard and areas of safety concern
- **Material safety data sheets (MSDSs)** that give much more detailed safety information than labels
- **Worker education** on pesticide hazards and **training** in safety procedures

Labels are provided on pesticide containers. Material safety data sheets are available from pesticide manufacturers through your local distributor. Worker education is based on label and MSDS information. And worker training is based on safe practices used in the workplace.





## Labels

---

Three types of labels are associated with pesticides: **supplier labels**, **workplace labels**, and **other means of identification**. Supplier labels must accompany pesticides when sold to the user. Workplace labels and other means of identification must be provided by the employer at the workplace (e.g., when pesticides are poured into other storage containers or are transferred in piping systems).

### Supplier labels

An example of a hypothetical supplier label is shown in Figure 1. Important sections of the supplier label include the following:

a) **Trade name**

This is the company brand name only. Often, it does not give the name of the actual chemical contained in the product. The trade name of the label in Figure 1 is Pestkill.

b) **Guarantee**

This important part of the label states two things:

- **The name of the chemical that is the actual pesticide in the product (called the *active ingredient*)**. The active ingredient in the example is the hypothetical chemical triazinon. Some pesticides contain and list more than one active ingredient.
- **The strength of the pesticide formulation**. No pesticides are sold for use as pure active ingredient. All are mixed with other materials (formulants) such as solvents, clays, or product enhancers. The mixtures are called *formulations*.

The strength of the active ingredient in the formulation is given in grams per litre or as a percentage of the total weight. To convert grams per litre to percent by weight, just divide by ten. In the example, the strength of the triazinon in Pestkill is 500 grams per litre, or roughly 50 percent of the mixture by weight. The higher the strength, the more hazardous the pesticide.

c) **Type of formulation**

Pesticides can be made as solids, liquids, or gases. A pesticide's ability to affect health often varies with the type of formulation. The pesticide shown in Figure 1 is formulated as a wettable powder.

d) **Pesticide use**

This gives information on what type of pest the product is meant to control. Three common types of pesticides are insecticides, fungicides, and herbicides. The pesticide in Figure 1 is an insecticide for control of a wide variety of insects.





Front of Container

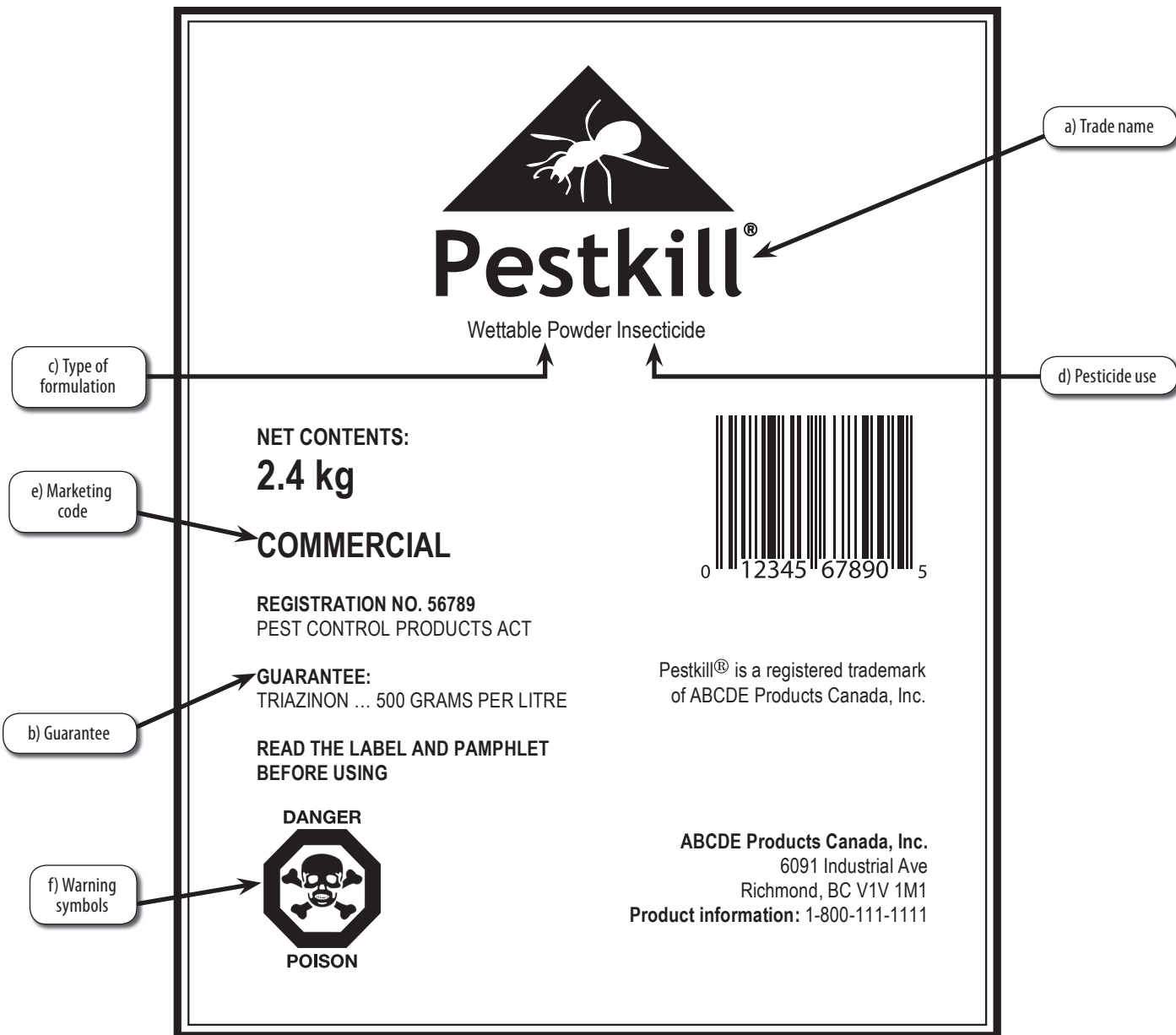

Figure 1: Sample supplier label





Back of Container

# Pestkill®

**WP INSECTICIDE  
COMMERCIAL**

**REGISTRATION NO. 56789**

PEST CONTROL PRODUCTS ACT

**GUARANTEE:**

TRIAZINON...500 GRAMS PER LITRE

**DANGER**

**POISON**

**ABCDE Products Canada, Inc.**

6091 Industrial Ave  
Richmond, BC V1V 1M1  
Product information: 1-800-111-1111

**READ THE LABEL AND  
PAMPHLET BEFORE USING**

**DIRECTIONS FOR USE:** Pestkill is a wettable powder that requires constant agitation during application. It is not for use by homeowners or other uncertified users. May be fatal if swallowed. Avoid contact with eyes and skin. Avoid breathing spray mist or vapours. Wash thoroughly after handling and before eating or drinking. Wear protective coveralls and chemical resistant gloves during mixing, loading, application, and cleanup activities. Wear NIOSH-approved respirator when spraying or during other activities where there is exposure to mist or vapours. The days-to-harvest interval is 14 days. The restricted entry interval is 72 hours. See attached pamphlet for information on application with specific crop types.

**DISPOSAL:** Triple rinse the empty container. Make the container unsuitable for other use. Dispose of the container in accordance with provincial requirements. For information on the disposal of unused product, contact the manufacturer or provincial regulatory agency. Contact the manufacturer and applicable provincial regulatory agencies in case of a spill and for cleanup of spills.

**FIRST AID AND TOXICOLOGICAL INFORMATION:** Symptoms of poisoning include headache, weakness, blurred vision, nausea, cramps, excess sweating, vomiting, convulsions, and coma. **First aid:** In case of poisoning, IMMEDIATELY contact the first aid attendant for the worksite, and if not available, call a physician or a poison control centre. Take label, MSDS, or product name and *Pest Control Products Act* registration number with you when seeking medical attention. IF SWALLOWED, call a poison control centre or doctor, and do not induce vomiting unless told to do so. Do not give anything by mouth to an unconscious patient. IF ON SKIN OR CLOTHING, take off contaminated clothing. Rinse skin immediately with plenty of water for a minimum of 15 minutes, and if necessary call a poison control centre or doctor for further treatment information. IF IN EYES, hold eye open and rinse gently with water for 30 minutes. If necessary, call a poison control centre or doctor for further treatment information. IF INHALED, move person to fresh air while protecting yourself from exposure. IF PERSON IS NOT BREATHING, call 911 or an ambulance, and give artificial respiration. **Toxicological information:** Triazinon is an organophosphate insecticide and a cholinesterase inhibitor. Atropine is an antidote. Use 1 to 2 mg every 15 to 30 minutes if necessary.

**NOTICE TO USER:** This pest control product is to be used only in accordance with the directions on the label. It is an offence under the *Pest Control Products Act* to use this product in a way that is inconsistent with the directions on the label. The user assumes the risk to persons or property that arises from any such use of the product.

**NET CONTENTS:**

## 2.4 kg

Pestkill® is a registered trademark  
of ABCDE Products Canada, Inc.

## Pestkill®

i) Company contact information

j) Registration number

g) Directions for use

h) First aid and toxicological information

Figure 1: Sample supplier label





---

e) **Marketing code**

Pesticide marketing codes specify one of the following:

- DOMESTIC
- COMMERCIAL
- RESTRICTED
- MANUFACTURING

Typically, DOMESTIC products are less hazardous than COMMERCIAL or RESTRICTED products because of lower strength or toxicity. (Note that the term MANUFACTURING applies if the product is to be used only in the manufacture of other pesticides. Products with this code are highly concentrated, and they must not be applied.)

f) **Warning symbols**

Visual warning symbols on pesticide labels indicate the kind of harm that can result from pesticide misuse. They can alert us to both the degree and the type of hazard.

- **Degree of hazard**

The degree of hazard is indicated by the shape of the symbol.

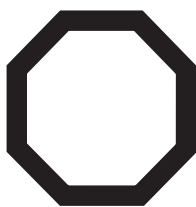

The eight-sided "stop sign" is a DANGER alert and is used with the most hazardous pesticides.

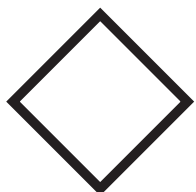

The four-sided diamond sign is a WARNING for a pesticide that is moderately hazardous.

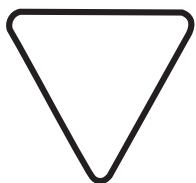

The three-sided triangle sign is a CAUTION that the pesticide is slightly hazardous.







– **Type of hazard**

The type of hazard is represented by the type of picture within the symbol. There are four types of hazards identified on labels.



The “skull and crossbones” symbol warns that the chemical is **POISONOUS** if taken into the body.



The “fire” symbol is a warning that the pesticide is **FLAMMABLE** or easily ignited.



The “exploding grenade” symbol indicates that the pesticide can **EXPLODE**. Pesticides in pressurized cans are an example.



The “corroded hand” symbol indicates that the pesticide is **CORROSIVE** to the skin. The chemical is either acid or alkali (caustic) and can burn the skin.

The warning symbol on the label for Pestkill identifies the product as a **DANGEROUS POISON**.

g) **Directions for use**

This section gives general information on how to use the product to safely control pests. It may include *days-to-harvest (pre-harvest) intervals*, which are minimum time periods between the application of the pesticide and the harvest of crops. These intervals are required in order to protect consumers from eating crops with high levels of pesticides.

Due to space constraints, directions for use may sometimes be found in a pamphlet attached to the label.

**Days-to-harvest intervals are not to be confused with *restricted entry intervals (or re-entry intervals)***, which are the periods of time that must pass before workers not wearing suitable personal protective equipment





---

are permitted to enter a work area such as a field, orchard, or building where pesticides have been applied. For the label in Figure 1, a restricted entry interval of 72 hours is specified.

h) **First aid and toxicological information**

This section provides a brief summary of poisoning symptoms and first aid advice. Information in Figure 1 emphasizes quick action to wash the victim. It also warns against inducing vomiting unless told to do so by a poison control centre or doctor.

i) **Company contact information**

You can use this information to request material safety data sheets. An MSDS gives much more detailed information on safety precautions with pesticides than the label.

j) **Registration number**

Pesticides for sale in Canada must display a registration number on the label. The number provides assurance that the product has been cleared with federal authorities. Contact the Pest Management Regulatory Agency (PMRA) of Health Canada if in doubt about a product that has no registration number. The PMRA's web site ([www.pmra-arla.gc.ca](http://www.pmra-arla.gc.ca)) features information on pesticide registrations.

## **Workplace labels and other means of identification**

Employers must provide workplace labelling when products such as pesticides are transferred at the workplace from supplier containers to other containers or to transfer systems.

The two types of workplace labelling are

- **Workplace labels**, which are required on containers used to store product for longer than a workshift. These labels provide three types of information:
  - The name of the product
  - Safe handling procedures
  - A reference to the material safety data sheet
- **Other means of identification**, which are required on equipment such as
  - Spray tanks that will be under the control of a pesticide applicator for use on one shift
  - Piping systems used to transfer pesticides in the workplace

This type of labelling will specify contents through a product identifier, colour, number code, or other visual means of recognizing contents.





## Material safety data sheets (MSDSs)

---

Material safety data sheets (or MSDSs) are an essential part of a pesticide information system. *Labels are not sufficient.*

MSDSs are designed to provide much more detailed information on pesticide hazards and controls than labels. For example, typically the only chemical listed on a label is the active ingredient. By contrast, the MSDS includes a section that lists the active ingredient as well as the other hazardous ingredients in the formulation. MSDSs also provide additional information on hazards, including the possibility of any chronic health effects, and more detailed information on protective measures.

MSDSs provide flexibility to the pesticide information system. As hazard information changes for a product, or as new safety procedures are devised, sheets can be upgraded easily. Because material safety data sheets are not attached to containers, they can be

- Filed in first aid kits
- Posted in work areas
- Provided to medical facilities to help with emergency treatment of workers

In Canada, the Workplace Hazardous Materials Information System (WHMIS) requires that MSDSs meeting legislated standards be provided to employers by suppliers for most industrial chemicals. Suppliers of pesticides in Canada are at this point exempt from this requirement, but Health Canada advises registrants to make MSDSs available.





---

## Sections of the MSDS

Typically, an MSDS will have at least nine sections, as outlined below:

### ***Section 1: Product Identification and Use***

This section identifies the product and describes its intended use. The Product Identification Number (PIN) is of assistance in emergencies. This section also provides information on both the manufacturer and supplier, including emergency phone numbers.

### ***Section 2: Hazardous Ingredients***

Space is provided for a list of hazardous ingredients in the formulation. Suppliers should list *all* active ingredients and formulants that exceed WHMIS hazard criteria.

### ***Section 3: Physical Data***

Provides detailed information related to

- Recognition of the material by odour and appearance
- The ability of the material to produce dangerous levels of vapour in air
- The likelihood the material is corrosive to the skin and eyes

### ***Section 4: Fire and Explosion Data***

This section lists the conditions under which the product may catch fire or explode, as well as information for developing strategies and procedures to deal with fire and explosion hazards.

This information is important to consider for

- Storage practices
- Control of sources of ignition near the material
- Firefighting

### ***Section 5: Reactivity Data***

This section lists conditions and other substances that should be avoided to prevent dangerous reactions. This is an important section to consider for both the storage and handling of the pesticide.

### ***Section 6: Toxicological Properties (Health Effects)***

This section identifies how the substance enters the body and the possible health effects from single or repeated exposures. It also identifies if the product has known long-term health effects such as liver or kidney damage, sensitization, cancer, or reproductive toxicity.





---

### ***Section 7: Preventive Measures***

This section includes information on

- Required protective equipment
- Engineering controls
- How to safely clean up spills
- How to safely use, handle, store, dispose of, and transport the product

This information is meant for the protection of all workers at risk of exposure. Where provided, restricted entry intervals, dislodgeable residue data, and enclosed space ventilation procedures can help protect re-entry workers.

### ***Section 8: First Aid Measures***

This section lists specific instructions for the immediate treatment of a worker who has inhaled or swallowed the product or who has had skin or eye contact with the product.

### ***Section 9: Preparation Data***

This section lists the date the MSDS was prepared and who prepared it.

See page 21 for a sample of a nine-section MSDS.





## MATERIAL SAFETY DATA SHEET — 9 Sections

### SECTION 1 — Product Information

Product Identifier			WHMIS Classification <i>(optional)</i>	
Product Use				
Manufacturer's Name			Supplier's Name	
Street Address			Street Address	
City		Province	City	
Postal Code		Emergency Telephone	Postal Code	
			Emergency Telephone	

### SECTION 2 — Hazardous Ingredients

Hazardous Ingredients <i>(specific)</i>	%	CAS Number	LD <sub>50</sub> of Ingredient <i>(specify species and route)</i>	LC <sub>50</sub> of Ingredient <i>(specify species)</i>

### SECTION 3 — Physical Data

Physical State	Odour and Appearance		Odour Threshold (ppm)
Specific Gravity	Vapour Density (air = 1)	Vapour Pressure (mmHg)	Evaporation Rate
Boiling Point (°C)	Freezing Point (°C)	pH	Coefficient of Water/Oil Distribution





### SECTION 4 — Fire and Explosion Data

Flammability <input type="checkbox"/> Yes <input type="checkbox"/> No	If yes, under which conditions?	
Means of Extinction		
Flashpoint (°C) and Method	Upper Flammable Limit ( <i>% by volume</i> )	Lower Flammable Limit ( <i>% by volume</i> )
Autoignition Temperature (°C)	Explosion Data — Sensitivity to Impact	Explosion Data — Sensitivity to Static Discharge
Hazardous Combustion Products		

### SECTION 5 — Reactivity Data

Chemical Stability <input type="checkbox"/> Yes <input type="checkbox"/> No	If no, under which conditions?
Incompatibility with Other Substances <input type="checkbox"/> Yes <input type="checkbox"/> No	If yes, which ones?
Reactivity, and Under What Conditions?	
Hazardous Decomposition Products	

### SECTION 6 — Toxicological Properties

Routes of Entry <input type="checkbox"/> Skin Contact <input type="checkbox"/> Skin Absorption <input type="checkbox"/> Eye Contact <input type="checkbox"/> Inhalation <input type="checkbox"/> Ingestion	
Effects of Acute Exposure to Product	
Effects of Chronic Exposure to Product	
Exposure Limits ( <i>value, source, date</i> )	Irritancy ( <i>if yes, explain</i> ) <input type="checkbox"/> Yes <input type="checkbox"/> No
Sensitization ( <i>if yes, explain</i> ) <input type="checkbox"/> Yes <input type="checkbox"/> No	Carcinogenicity ( <i>if yes, explain</i> ) <input type="checkbox"/> Yes <input type="checkbox"/> No
Reproductive Toxicity ( <i>if yes, explain</i> ) <input type="checkbox"/> Yes <input type="checkbox"/> No	Teratogenicity ( <i>if yes, explain</i> ) <input type="checkbox"/> Yes <input type="checkbox"/> No
Mutagenicity ( <i>if yes, explain</i> ) <input type="checkbox"/> Yes <input type="checkbox"/> No	Synergistic Products ( <i>if yes, explain</i> ) <input type="checkbox"/> Yes <input type="checkbox"/> No





**SECTION 7 — Preventive Measures**

Personal Protective Equipment	
<input type="checkbox"/> Gloves	<input type="checkbox"/> Respirator
<input type="checkbox"/> Eye	<input type="checkbox"/> Footwear
<input type="checkbox"/> Clothing	<input type="checkbox"/> Other
If checked, specify type	
Engineering Controls ( <i>specify, such as ventilation, enclosed process</i> )	
Leak and Spill Procedure	
Waste Disposal	
Handling Procedures and Equipment	
Storage Requirements	
Special Shipping Information	PIN

**SECTION 8 — First Aid Measures**

Inhalation
Ingestion
Skin Contact
Eye Contact

**SECTION 9 — Preparation Information**

Prepared by ( <i>group, department, etc.</i> )	Telephone Number	Preparation Date
--	------------------	------------------







## Worker education and training

---

Employers must provide instruction and information to workers on the safe use of pesticides. The instruction, based in good part on information from labels and MSDSs, will include

- **Education** in the hazards of pesticides
- **Training** in procedures to be followed
  - For the safe storage, handling, use, and disposal of pesticides
  - In case of an emergency
  - When airborne or other emissions from pesticides are present

Workers must be instructed if they

- Store, handle, use, or dispose of pesticides, or supervise workers performing those duties, *or*
- Work near the product such that their health and safety could be at risk. Examples include
  - Working near pesticide storage, handling, use, or disposal areas
  - Re-entry into treated areas
  - Handling materials treated with pesticides
  - Maintenance of pesticide equipment or facilities

The objective of the program of instruction must be to ensure that workers are able to *apply* the information to protect their health and safety.

The program of instruction must be developed and implemented in consultation with the joint occupational health and safety committee or representative, as applicable.

The program must be reviewed at least once a year or more often if conditions at the workplace or information on the product changes the risk to workers.





# 3

## Types of pesticides

**This chapter includes the following sections:**

- Introduction
- Classifying by target organism
- Classifying by formulation
- Classifying by chemical family







## Introduction

---

Many people find the topic of pesticides confusing. After all, there are about 6,000 pesticide formulations on the Canadian market.

But there are two steps you can take to simplify things and improve your understanding of pesticides.

### Step 1

**Learn the common chemical name of the active ingredient in the formulation, along with the trade name.** For every one active ingredient sold in Canada, there are about six trade names, and one name is easier to learn than six. Chemical names are also helpful because information from the Internet, libraries, and public agencies is often listed by chemical rather than by trade name.

Common chemical names are generally short and easy to learn. They often appear on pesticide labels after the word GUARANTEE. For example, pesticides with brand names such as Laddock, Aatrex, Marksman, Primextra, and Shotgun all guarantee the active ingredient with the common chemical name atrazine.

### Step 2

**Learn to organize or group the many pesticides into a few types.** By doing this, you can learn about things such as

- The ways pesticides enter the body
- Symptoms of poisoning
- Treatment of poisoning
- Persistence of pesticides in the environment

Three useful ways to classify pesticides are by

- Target organism
- Type of formulation
- Chemical family of the active ingredient in the pesticide



## Classifying by target organism

---

In this case, pesticides are classified according to the type of pest they are meant to control. As shown in Table 1, three of the most common types of pesticides are insecticides, herbicides, and fungicides.

**Table 1: Types of pesticides — by target organism**

Type of pesticide	Target pest	Example
<b>COMMON TYPES</b>		
Insecticides	Insects	Malathion
Herbicides	Weeds or parts of crops	Amitrole
Fungicides*	Fungi (molds, mildews, and plant disease)	Chlorothalonil
<b>LESS COMMON TYPES</b>		
Avicides	Birds	Aminopyridine
Miticides	Mites	Dicofol
Molluscicides	Snails, slugs	Metaldehyde
Nematicides	Nematodes	Methyl bromide
Rodenticides	Rodents	Warfarin

\* Fungicides include many of the products used for anti-sapstain and wood preservative applications in the wood products industry. Examples include propiconazole and ACQ (copper ethanolamine complex).

By grouping pesticides this way, we learn that

- Insecticides are often more likely to cause severe short-term (acute) health effects than herbicides and fungicides.
- A number of fungicides can cause skin irritation or allergy.
- Many of the rodenticides reduce the clotting ability of the blood, and can result in poisoning symptoms such as nosebleeds and severe back and stomach pains.



## Classifying by formulation

---

Pesticides are almost never sold or used as pure active ingredients. Usually, the active ingredient is combined with other materials (called *formulants*) in a mixture called a *formulation*.

There are two issues to consider when classifying by formulation: formulants, and the physical nature of the formulation.

### Formulants

Sometimes formulants have been called *inerts*, but this is misleading. Formulants can contribute substantially to the effectiveness of the active ingredient, and they are often hazardous to workers.

For example, many formulants are flammable and present fire hazards. In some cases, formulants are oxidizers and can contribute to the chance of fire if they contact a flammable material. Some formulants are acids or caustics and can burn the skin or eyes.

In addition, formulants can be toxic to people. The Pest Management Regulatory Agency maintains an extensive list of formulants on its web site, [www.pmla-arla.gc.ca](http://www.pmla-arla.gc.ca). The list includes toxic materials such as

- Silica
- Toluene diisocyanate
- Formaldehyde
- Methyl chloride
- Phenol
- Various chromium compounds

Unfortunately, formulants are often not listed on labels. However, the material safety data sheets (MSDSs) required by WHMIS contain a section for reporting hazardous ingredients. While pesticide suppliers are exempt from WHMIS, they have been encouraged to provide MSDSs.

### Physical nature of the formulation

The hazards of formulations depend in part on whether they are used in the solid, liquid, or gaseous state. Specific types of formulations include dusts, granules, wettable powders, emulsifiable concentrates, and fumigants. The hazards of various types of formulations are shown in Table 2.





**Table 2: Types of pesticide formulations— hazard properties**

Type of formulation	Description of formulation	Hazard properties of formulation
<b>SOLIDS</b>		
Dusts	Finely powdered solid material. Active ingredient may be mixed with clays, diatomaceous earth (DE), or talc (which in some cases may contain asbestos).	Dusts drift easily in the air and can be inhaled. DE contains up to 90% free silica, a potential cause of silicosis.
Granules	Larger aggregates than dusts. Slightly more coarse than sugar.	Not as much of a drift hazard as dusts, but can be easily dislodged from treated surfaces. Are often fairly persistent in the environment because of slow release characteristics.
Pellets	Larger aggregates than granules.	Less drift hazard than granules. May be quite persistent due to physical size.
<b>LIQUIDS</b>		
Emulsifiable concentrates (EC)	An active ingredient dissolved in an organic liquid with an emulsifying agent to permit further mixing with water.	Organic liquids, such as xylene, can be highly flammable. They may also cause drowsiness in highly exposed workers and can increase pesticide penetration of skin.
Wettable powders (WP)	A finely ground powder that contains active ingredient and diluents. WPs are applied as suspensions in water.	In dry form, can drift easily and be inhaled. More physically corrosive to application equipment than ECs. Tend to persist longer in the environment and are more easily dislodged from foliage than ECs.
Encapsulated materials	Pesticide contained in capsule of poly-vinyl or a gelatinous material.	Capsule increases persistence. Less hazardous to applicators than some other formulations. May rupture if overheated.
Fogs	Composed of tiny airborne liquid droplets. May be applied in a carrier such as kerosene.	Fogs drift easily. Oil-based fogs present fire hazards.
<b>GASES</b>		
Fumigants	Exist as a gas, vapour, or smoke. May be produced from contact of a solid chemical with water or from evaporation of a liquid, or may be sold as pressurized gases in cans.	Often highly toxic. Drift easily and can affect workers far from application site unless control steps are taken.





## Classifying by chemical family

---

Most pesticides in use are chemicals. Many of them can be grouped into a relatively small number of chemical families. A *chemical family* is a group of chemicals that have a similar chemical composition, and as a result have similar properties, including hazards for workers.

In order to use pesticides safely, it is necessary to understand some basic facts about chemical families.

An understanding of chemical families can be used to predict

- Symptoms of poisoning
- Treatment of poisoning
- Persistence of a chemical after application
- The nature of breakdown products from the parent pesticide
- The type of spill cleanup procedure required

Workers do not have to be chemists to understand how chemical families are important to their safety. It is far easier to learn about a few families or groups than hundreds of individual pesticides.

The learning process becomes even easier when we realize that, of the various groups, several are the most common, such as *organophosphates* and *carbamates*.

Table 3 provides an overview of chemical families. In the next chapter, these groups will be used to help readers understand the symptoms and treatment of pesticide poisoning.







**Table 3: Types of pesticides — by chemical family**

<b>Common types</b>		
<b>Chemical family</b>	<b>Nature of chemical</b>	<b>Examples</b>
Organophosphates	All are insecticides containing the phosphate group. Some contain sulfur and can form toxic by-products called “oxons.” Often identified by endings in chemical names such as “-phos” and “-fos,” and for sulfur products, “-thion.”	Azinphos-methyl Chlorpyrifos Diazinon Malathion
Carbamates	All contain nitrogen. Can be either insecticides or fungicides. Fungicides contain sulfur; insecticides do not. Insecticides are often identified by the use of the term “carb” in chemical names.	<i>Insecticides:</i> Carbaryl Carbofuran Methomyl  <i>Fungicides:</i> Ferbam Zineb
Organochlorines	All contain chlorine. Can be insecticides or fungicides. The fungicides contain sulfur as well.	<i>Insecticides:</i> Endosulfan  <i>Fungicides:</i> Captan
<b>Other types</b>		
<b>Chemical family</b>	<b>Examples</b>	
Anticoagulant rodenticides	Warfarin, diphacinone, chlorophacinone	
Bipyridines	Diquat, paraquat	
Botanicals	Pyrethrin, rotenone	
Inorganics	Lime sulfur, sodium chlorate	
Organonitrogens	Atrazine, simazine	
Phenoxy herbicides	2,4-D, MCPA	





# 4

## Routes of entry and health effects

**This chapter includes the following sections:**

- Routes of entry – how pesticides enter the body
- Health effects







## Routes of entry—how pesticides enter the body

---

Pesticides can be absorbed into the body by three routes:

- Through the skin (dermal absorption)
- Through the lungs (inhalation)
- By mouth through the stomach and intestines (ingestion)

In typical work situations, skin absorption is the major route of entry of pesticides into the body. A review has shown that more than four out of five accepted compensation claims involved exposure of the skin.

### Skin absorption

Pesticides are formulated to be absorbed easily through the surface tissue of pests. Similarly, the skin is a major route of human exposure.

The ability of skin to absorb pesticide depends on a number of factors:

- **Skin condition**  
Absorption is a particular hazard with skin that has been cut or scraped. A cut can increase pesticide absorption by 100,000 times! Sweating will assist pesticide absorption.
- **Skin location**  
As shown in Figure 2, the eyes and genital area absorb pesticides more easily than the forearms or hands. This is why the use of eye protection and hygiene practices is important. Of course, the hands and any other area of the body likely to come in contact with pesticides must be protected as well.
- **Type of pesticide**  
For example, less than one percent of the herbicide diquat applied to the forearm is absorbed, compared with 16 percent for the insecticide azinphos-methyl. The Table of Exposure Limits for Chemical and Biological Substances found at [WorkSafeBC.com](http://WorkSafeBC.com) includes a “Skin” notation for substances that contribute significantly to overall exposure by the skin route. Some of the substances listed in the table are pesticides.
- **Nature of formulation**  
Emulsifiable concentrates (ECs) often contain an organic solvent such as xylene, which is soluble in fatty tissue and promotes the absorption of the pesticide. Some formulants are acidic or caustic and can damage the skin. Others, such as phenol, can be absorbed by the skin and cause damage internally. If not handled carefully, wettable powders can produce airborne dust that may settle on the skin, as well as enter the lungs.





- **Nature of the job**

For example, workers are particularly at risk of poisoning by skin absorption when mixing pesticides because they are handling concentrated pesticides that contain a relatively high percentage of active ingredient.

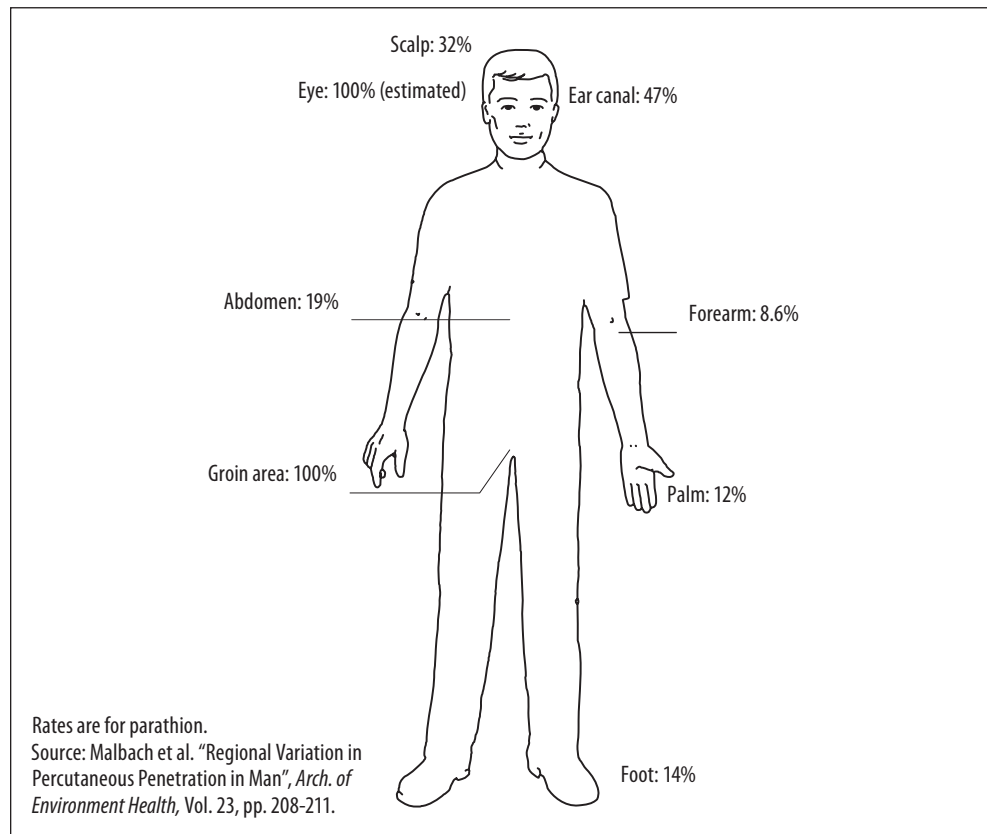

**Figure 2: Skin absorption of pesticides**

## **Inhalation (breathing in)**

The chance of a worker inhaling a pesticide is higher with pesticides that tend to remain suspended in the air after application. For example, fine sprays are more likely to be inhaled than coarse sprays. Fine dusts, fogs, and gas fumigants (such as methyl bromide) are more likely to be inhaled than sprays or granular formulations. For fumigants, inhalation is typically the main route of entry into the body.

Enclosed workplaces such as greenhouses, mushroom barns, and warehouses may be particularly hazardous because of the high level of airborne pesticides that may result from poor ventilation.





---

## Ingestion (swallowing)

While skin absorption is the most common means of exposure, the most severe poisonings often result when pesticides are accidentally taken by mouth.

It takes a surprisingly small amount of chemical to cause severe poisoning effects when swallowed. This is because of the high absorbing capability of the stomach and intestines.

Workers are at risk of swallowing pesticide if they do not wash hands prior to eating or drinking. A study has shown that people with contaminated hands swallowed measurable amounts of pesticide while eating lunch.

Some pesticide containers resemble drinking containers, but they must never be confused as such. It is particularly essential that non-literate workers be instructed in the meaning of symbols on such products.

In addition, all empty pesticide containers must be rinsed and disposed of according to regulations. They must never be used for other purposes.

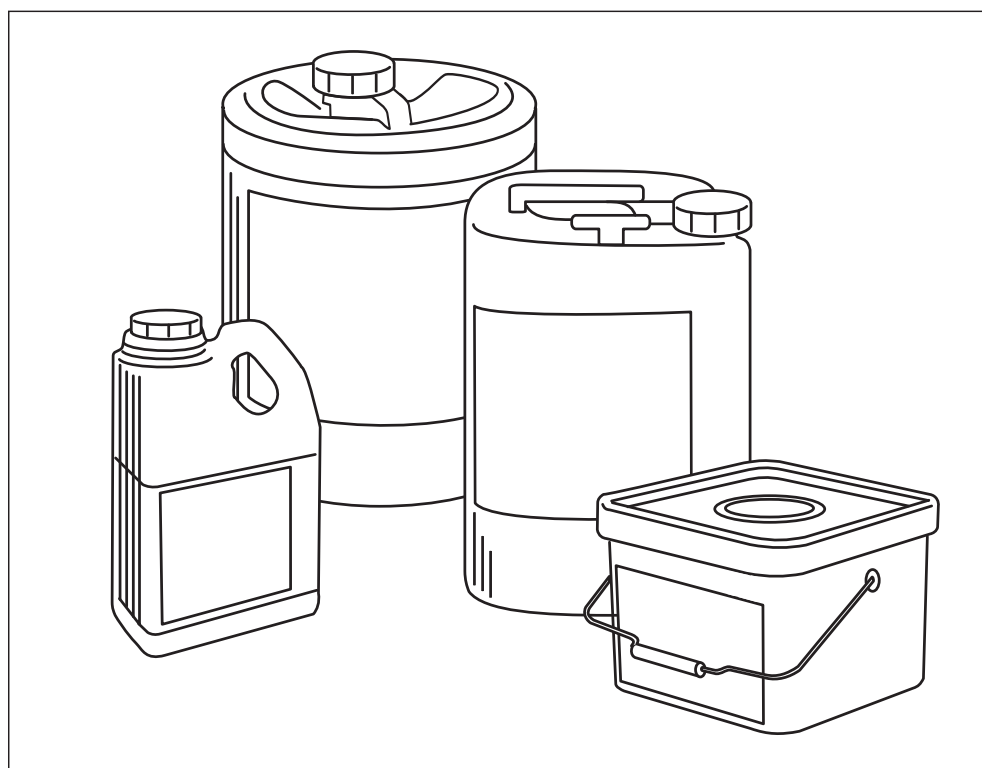

**Figure 3: Shapes of pesticide containers**





## Health effects

---

Poisonous effects of pesticides can either be acute (short-term) or chronic (long-term). All pesticides can produce acute symptoms; some can also cause chronic problems.

### Acute (short-term) effects

These generally result when a substantial amount of pesticide has been absorbed into the body. This can happen, for example, when workers splash pesticides on themselves while mixing pesticide formulations, or if unprotected workers are exposed to drift during spraying.

The following section outlines four basic things to remember about acute effects:

- **Mild poisoning symptoms may be vague and can be confused with common infective conditions such as the flu.**

Typical symptoms include

- Nausea
- Headache
- Tightness in the chest
- Loss of appetite
- Stomach cramps

Do not attempt a self-diagnosis. Get help right away.

- **The full effects of poisoning may not occur right away.**  
Sometimes the full impact of a poisoning, especially in cases of skin absorption, will take up to 12–24 hours to happen. It is important to take even minor symptoms seriously if there is a possibility of pesticide poisoning.

- **Symptoms of severe poisoning are often specific in nature and require immediate hospital treatment.**

Typical symptoms include

- Vomiting and diarrhea
- Excessive sweating
- Difficulty in breathing
- Collapse, convulsions, and coma

Some types of pesticides produce very specific effects. For example, exposure to organophosphates (OPs) and carbamates (CBs) can result in pinpoint pupils (a condition called miosis).





- **A rough measure of the ability of a pesticide to cause acute poisoning symptoms is its LD<sub>50</sub> number.**

The LD<sub>50</sub> of a pesticide refers to the **Lethal Dose** of the pesticide required to kill half (**50 percent**) of a group of test animals such as rats or mice.

In typical experiments, test animals are either fed the pesticide or have the chemical administered to the skin. Dosages are increased until a given dose kills half the test animals. That amount is called the LD<sub>50</sub> and is measured in milligrams of pesticide per kilogram of body weight of the test animal. If the chemical is fed to the test animal, it is referred to as the *oral LD<sub>50</sub>*; if applied to the skin, the *dermal LD<sub>50</sub>*. The dermal LD<sub>50</sub> is generally greater than the oral LD<sub>50</sub>.

Pesticides can be put into one of three acute toxicity groups on the basis of LD<sub>50</sub>s, as follows.

Acute toxicity groups for pesticides		
Toxicity group	Oral LD <sub>50</sub>	Dermal LD <sub>50</sub>
Very toxic	0–50 mg/kg	0–200 mg/kg
Moderately toxic	Over 50–500 mg/kg	Over 200–1,000 mg/kg
Slightly toxic	Over 500 mg/kg	Over 1,000 mg/kg

NOTE: To classify a pesticide for which both oral and dermal LD<sub>50</sub>s are given, choose the more restrictive category. For example, glufosinate ammonium, which has an oral LD<sub>50</sub> of as little as 416 in mice (moderately toxic) and a dermal LD<sub>50</sub> of 2,000 or more (slightly toxic), is considered overall to be a moderately toxic pesticide. Where a range of LD<sub>50</sub>s is reported for a given route of exposure, choose the lowest number.

To put LD<sub>50</sub> numbers in human terms, consider the following examples:

- Azinphos-methyl is a *very toxic* pesticide with an oral LD<sub>50</sub> of 7. A fraction of a teaspoon of pure active ingredient, if swallowed by an adult, could induce death.
- For the *moderately toxic* chlorpyrifos, with an oral LD<sub>50</sub> of 82, the fatal dose of pure material is predicted to be as little as one tablespoon (15 millilitres).
- For the *slightly toxic* simazine (oral LD<sub>50</sub> = 5,000), the fatal quantity of pure pesticide may be about 16 fluid ounces (0.5 litre).

These predictions are approximate because it is difficult to know if a person will react to a chemical in the same way as a rat or mouse. When pure pesticide is diluted, the amount required to cause a fatality is correspondingly increased.

For more information on acute toxicity of specific pesticides, refer to Table 4 in this chapter.

#### Note

- The *smaller* the LD<sub>50</sub> of a pesticide, the more acutely toxic it is.
- LD<sub>50</sub>s help predict *acute* toxicity only. They do *not* measure the ability of a pesticide to cause chronic health problems.
- The toxicity of gases is measured as a lethal concentration (LC<sub>50</sub>).







---

## Chronic (long-term) effects

Chronic problems resulting from exposure to some pesticides can include a variety of effects such as

- Skin or lung sensitization
- Nerve, liver, or kidney problems
- Cancer, reproductive problems, or other effects in some cases

Chronic effects may be due to exposure to the active ingredient or to a formulant that has toxic properties. For example, the active ingredient alachlor is a skin sensitizer. Toluene diisocyanate (TDI) is a formulant and is both a skin and respiratory sensitizer.

Chronic effects typically occur in one of three ways:

- **As a complication of acute poisoning.** For example, leptophos, an organophosphate insecticide, may produce persistent nerve damage after an incident of acute poisoning.
- **As a slowly progressive condition** without any incident of acute poisoning. For example,
  - Increased breathing difficulty in workers using Bordeaux Mixture in powder form
  - Skin or respiratory sensitization (allergy) for some workers exposed to pesticides such as alachlor, formaldehyde, and pyrethrum
- **As the development of a cancer.** For example, arsenical fungicides have been found to cause cancer.

The last two types of chronic effects are most likely to occur in workers who have had prolonged exposure to the pesticide.

Refer to Table 5 in this chapter for more information on the possible chronic effects of pesticides. The table includes active ingredients and formulants of many pesticides. In addition, the Table of Exposure Limits for Chemical and Biological Substances found at [WorkSafeBC.com](http://WorkSafeBC.com) lists the designations of chemicals as carcinogens, reproductive toxins, and sensitizers.





## Getting health information on pesticides

This section offers directions for using the following tables:

- Table 4: Acute toxicities of pesticides
  - Table 5: Health effects of some major classes of pesticides
1. First, find out the **common chemical name** of your pesticide formulation. It is provided in small print below the company **trade name** on the pesticide label and beside the word "Guarantee."
  2. Then go to **Table 4, Acute toxicities of pesticides**, which lists the common chemical names (in some cases followed by trade names) for most pesticides. For each pesticide, the oral LD<sub>50</sub> is listed as one measure of its acute toxicity. Pesticide ratings (*very toxic, moderately toxic, or slightly toxic*) are based on evaluation of both oral and dermal LD<sub>50</sub>s.
  3. Table 4 also provides the **target use** and **chemical family** for each pesticide. Use this information to go to **Table 5, Health effects of some major classes of pesticides**, which lists the acute and chronic poisoning symptoms of a number of pesticides, according to these classes.

For example, diazinon is an insecticide that belongs to the organophosphate (OP) chemical family. As shown in Table 5, OP insecticides can cause acute poisoning symptoms such as headache, blurred vision, sweating, and so on. Like all other organophosphates, the effects of diazinon exposure can be cumulative if a person is exposed repeatedly day after day. This is because it can take the body up to two to three weeks to replace the body enzyme that organophosphates affect.

In Tables 4 and 5, the names of chemical families of pesticides are abbreviated as follows:

AC	Anticoagulant rodenticides	ON	Organonitrogens
BP	Bipyridines	OP	Organophosphates
CB	Carbamates	PH	Phenoxy herbicides
FUM	Fumigants*	PY	Pyrethroids
IN	Inorganics	ML	Miscellaneous
OC	Organochlorines		

\* Fumigants are a group of pesticides that produce their toxic effect as gases or vapours. Technically, fumigants are not a chemical family. But because of their unique risks as inhalation hazards, they are identified in Table 4, and for convenience they are included in the "Chemical family" column. Inhalation hazards of fumigants may be significant regardless of LD<sub>50</sub>s (which are based on oral or dermal exposure), and this is reflected in the last column of Table 4.



**Table 4: Acute toxicities of pesticides**

<b>Chemical name (Trade name)</b>	<b>Major use (Target pest)</b>	<b>Chemical family</b>	<b>Oral LD<sub>50</sub></b>	<b>Acute toxicity rating</b>
Abamectin (Agri-Mek, Avid)	Insecticide	ML	12	VERY
Acephate (Orthene, Ortran)	Insecticide	OP	866	SLIGHTLY
Acrolein	Herbicide	ML	46	VERY
Alachlor (Lasso)	Herbicide	ML	1,200	SLIGHTLY
Allethrin	Insecticide	PY	680	SLIGHTLY
Alpha-chlorohydrin (Epibloc)	Rodenticide	ML	127	MODERATELY
Aluminum phosphide	Insecticide	FUM	9	INHALATION HAZARD
4-aminopyridine (Avitrol)	Repellent	ML	20	VERY
Amitraz (Apirar, Mitak)	Insecticide	ON	400	MODERATELY
Amitrole (Amizol, Cytrol)	Herbicide	ON	1,100	SLIGHTLY
Ammoniacal copper arsenate (ACA)	Fungicide/wood preserv.	IN	8	VERY
Ancymidol (A-rest)	Growth regulator	ML	2,000+	SLIGHTLY
Arsenic pentoxide (See CCA)				
Atrazine (Aatrex)	Herbicide	ON	1,780	SLIGHTLY
Azamethiphos	Insecticide	OP	1,040	SLIGHTLY
Azinphos-methyl (Guthion, Sniper)	Insecticide	OP	7	VERY
Bacillus thuringiensis (Dipel, Thuricide)	Insecticide	ML	15,000+	SLIGHTLY
Bensulide	Herbicide	ML	770	SLIGHTLY
Bentazon (Basagren)	Herbicide	ML	1,100	SLIGHTLY
Boric acid (Boracic acid)	Insecticide	ML	3,000	SLIGHTLY
Brodifacoum (Talon, Ratak)	Rodenticide	AC	0.3	VERY
Bromacil	Herbicide	ML	5,200	SLIGHTLY
Bromadiolone (Bromone)	Rodenticide	AC	1	VERY
Bromoxynil (Brominal)	Herbicide	NP	190	MODERATELY
Captan (Orthocide)	Fungicide	OC	8,400	SLIGHTLY
Carbaryl (Sevin)	Insecticide	CB	400	MODERATELY
Carbathiin (Arrest)	Fungicide	ML	3,200	SLIGHTLY
Carbofuran (Furadan)	Insecticide	CB	5	VERY
Chlormequat	Growth regulator	OC	440	MODERATELY
Chloroneb (Demosan)	Fungicide	ML	5,000+	SLIGHTLY
Chlorophacinone	Rodenticide	AC	20	VERY
Chloropicrin	Fungicide/nematicide	FUM	1	INHALATION HAZARD
Chlorothalonil (Bravo, Daconil)	Fungicide	ML	10,000	SLIGHTLY
Chlorpropham (Chloro-IPC)	Herbicide	ML	3,800	SLIGHTLY
Chlorpyrifos (Dursban, Lorsban)	Insecticide	OP	82	MODERATELY



**Table 4: Acute toxicities of pesticides (continued)**

<b>Chemical name (Trade name)</b>	<b>Major use (Target pest)</b>	<b>Chemical family</b>	<b>Oral LD<sub>50</sub></b>	<b>Acute toxicity rating</b>
Chlorsulfuron	Herbicide	ML	5,500	SLIGHTLY
Chlorthal (Dacthal)	Herbicide	ML	3,000	SLIGHTLY
CCA (chromated copper arsenate)	Fungicide/wood preserv.	IN	8	VERY
Clopyralid	Herbicide	ML	5,000	SLIGHTLY
Copper ethanolamine complex (ACQ)	Fungicide/wood preserv.	IN	1,682	SLIGHTLY
Copper naphthenate (Cuprinol)	Fungicide/wood preserv.	IN	450	MODERATELY
Copper oxychloride	Fungicide	IN		SLIGHTLY
Copper-8-quinolate (PQ8)	Fungicide/wood preserv.	IN	10,000+	SLIGHTLY
Coumaphos (Co-Ral)	Insecticide	OP	13	VERY
Creosote	Fungicide/wood preserv.	ML	725	SLIGHTLY
Cypermethrin	Insecticide	PY	251	MODERATELY
2,4-D	Herbicide	PH	300	MODERATELY
Daminozide (Alar, B-Nine)	Growth regulator	ML	8,400	SLIGHTLY
Dazomet (Basamid, Mylone)	Fungicide/nematicide	FUM	320	INHALATION HAZARD
Deet	Insecticide	ML	1,950	SLIGHTLY
Deltamethrin	Insecticide	ML	128	MODERATELY
Desmedipham	Herbicide	CB	8,000	SLIGHTLY
Diazinon	Insecticide	OP	300	MODERATELY
Dicamba (Dyvel)	Herbicide	ML	1,000	SLIGHTLY
Dichlobenil (Casoron)	Herbicide	ML	2,700	SLIGHTLY
Dichlofluanid	Fungicide/wood preserv.	ML	500	MODERATELY
Dichloran (Botran)	Fungicide	ML	1,500	SLIGHTLY
Dichloropropene (Telone)	Fungicide/nematicide	FUM	100	INHALATION HAZARD
Dichlorvos	Insecticide	OP	25	VERY
Diclofop-methyl (Hoe-Grass)	Herbicide	PH	563	SLIGHTLY
Dicofol (Kelthane)	Insecticide	OC	575	MODERATELY
Didecyl dimethyl ammonium chloride	Fungicide/wood preserve.	ML	450	MODERATELY
Difenzoquat (Avenge)	Herbicide	ML	270	MODERATELY
Diflubenzuron	Insecticide	OC	4,640	SLIGHTLY
Dimethoate (Cygon, Rogor)	Insecticide	OP	215	MODERATELY
Dinocap (Karathane, Mildex)	Fungicide	NP	980	SLIGHTLY
Diphacinone	Rodenticide	AC	2	VERY
Diquat (Reglone, Weedrite)	Herbicide	BP	215	MODERATELY
Diuron (Karmex)	Herbicide	ON	3,400	SLIGHTLY
Dodemorph-acetate	Fungicide	ML	2,500	SLIGHTLY



**Table 4: Acute toxicities of pesticides (continued)**

<b>Chemical name (Trade name)</b>	<b>Major use (Target pest)</b>	<b>Chemical family</b>	<b>Oral LD<sub>50</sub></b>	<b>Acute toxicity rating</b>
Dodine (Cyprex, Equal)	Fungicide	ML	566	SLIGHTLY
Endosulfan (Thiodan)	Insecticide	OC	18	VERY
Endothall (Des-i-cate)	Herbicide	ML	38	VERY
EPTC (Eptam, Eradicaine)	Herbicide	CB	1,400	SLIGHTLY
Ethephon (Ethrel)	Growth regulator	ML	4,229	SLIGHTLY
Ethofurnesate	Herbicide	ML	5,650	SLIGHTLY
Etridiazole	Fungicide	ON	1,077	SLIGHTLY
Famoxadone	Fungicide	ON	5,000+	SLIGHTLY
Famphur	Insecticide	OP	36	VERY
Fenamidone	Fungicide	ON	2,028	SLIGHTLY
Fenbutatin oxide	Insecticide	ML	2,630	SLIGHTLY
Fenhexamid (Decree)	Fungicide	ON	5,000+	SLIGHTLY
Ferbam	Fungicide	CB	1,000	SLIGHTLY
Fluazifop-butyl (Fusilade)	Herbicide	ML	3,328	SLIGHTLY
Flusilazole (Nustar)	Fungicide	ON	674	SLIGHTLY
Folpet (Phaltan)	Fungicide	OC	10,000	SLIGHTLY
Formaldehyde (Formalin)	Fungicide/microbicide	FUM	800	INHALATION HAZARD
Formetanate hydrochloride	Miticide	ML	15	VERY
Fosamine ammonium (Krenite)	Herbicide	ML	10,200	SLIGHTLY
Gibberellic acid (Activol)	Growth regulator	ML	6,300	SLIGHTLY
Glufosinate ammonium	Herbicide	ML	416	MODERATELY
Glyphosate (Roundup)	Herbicide	ML	4,300	SLIGHTLY
Hexazinone (Velpar)	Herbicide	ON	1,700	SLIGHTLY
Iprodione (Glycophene, Rovral)	Fungicide	ML	3,700	SLIGHTLY
Kinoprene (Enstar)	Insecticide	ML	5,000	SLIGHTLY
Imazamethabenz (Assert)	Herbicide	ON	5,000+	SLIGHTLY
Imazamox	Herbicide	ON	5,000+	SLIGHTLY
Imazapyr (Arsenal)	Herbicide	ON	5,000+	SLIGHTLY
Imazethapyr	Herbicide	PY	5,000+	SLIGHTLY
Imiprothrin	Herbicide	ON	900	SLIGHTLY
Isoxaben (Gallery)	Herbicide	ON	5,000+	SLIGHTLY
Lime sulfur	Fungicide, insecticide	IN	800	SLIGHTLY
Lindane	Insecticide	OC	88	MODERATELY
Linuron (Afolan)	Herbicide	ML	1,500	SLIGHTLY
Malathion (Cythion)	Miticide	OP	1,000	SLIGHTLY



**Table 4: Acute toxicities of pesticides (continued)**

<b>Chemical name (Trade name)</b>	<b>Major use (Target pest)</b>	<b>Chemical family</b>	<b>Oral LD<sub>50</sub></b>	<b>Acute toxicity rating</b>
Maleic hydrazide (De-sprout)	Herbicide	ML	1,400	SLIGHTLY
Mancozeb	Fungicide	CB	7,500	SLIGHTLY
Mandipropamid	Fungicide	ON	5,000+	SLIGHTLY
Maneb	Fungicide	CB	1,000	MODERATELY
MCPA (Agritox)	Herbicide	PH	700	SLIGHTLY
MCPB (Control)	Herbicide	PH	680	SLIGHTLY
Mecoprop (MCP)	Herbicide	PH	800	SLIGHTLY
Mesotrione	Herbicide	ML	5,000+	SLIGHTLY
Metalaxyl (Ridomil, Apron)	Fungicide	ML	870	SLIGHTLY
Metaldehyde (Slug bait)	Molluscicide	ML	600	SLIGHTLY
Metam-sodium (Vapam)	Fungicide/wood preserv.	FUM	820	INHALATION HAZARD
Methamidophos (Monitor)	Insecticide	OP	19	VERY
Methomyl (Lannate, Nudrin)	Insecticide	CB	17	VERY
Methyl bromide	Insecticide	FUM	21	INHALATION HAZARD
Methyl nonyl ketone (Detour)	Animal repellent	ML	10,000	SLIGHTLY
Metiram (Polyram)	Fungicide	CB	6,200	SLIGHTLY
Metribuzin (Sencor)	Herbicide	ML	1,100	SLIGHTLY
Myclobutanil	Fungicide	ON	1,100	SLIGHTLY
Nabam (Dithane, Kemtreet)	Fungicide	CB	395	MODERATELY
Naled (Bromex)	Insecticide	OP	250	MODERATELY
Naphthalene acetamide	Growth regulator	ML	1,000	SLIGHTLY
Naphthalene acetic acid	Growth regulator	ML	5,900	SLIGHTLY
Napropamide (Devrinol)	Herbicide	ML	4,640+	SLIGHTLY
Naptalam (Alanap)	Herbicide	ML	1,700	SLIGHTLY
Niclosamide	Molluscicide	ML	500	MODERATELY
Nicotine	Insecticide	ML	50	VERY
Novaluron (Rimon)	Insecticide	ML	5,000+	SLIGHTLY
Oxamyl	Nematicide	CB	5	VERY
Oxycarboxin	Fungicide	ML	2,000	SLIGHTLY
Oxyfluorfen (Goal)	Herbicide	ML	5,000+	SLIGHTLY
Paraquat (Gramoxone)	Herbicide	BP	140	MODERATELY
Parathion	Insecticide	OP	3	VERY
Pebulate (Tillam)	Herbicide	ML	920	SLIGHTLY
Pendimethalin	Herbicide	ON	1,050	SLIGHTLY
Pentachlorophenol	Fungicide/wood preserv.	OC	125	MODERATELY



**Table 4: Acute toxicities of pesticides (continued)**

Chemical name (Trade name)	Major use (Target pest)	Chemical family	Oral LD <sub>50</sub>	Acute toxicity rating
Permethrin (Ambush, Ectiban)	Insecticide	ML	4,000	SLIGHTLY
Phenmedipham	Herbicide	CB	8,000+	SLIGHTLY
Phorate	Insecticide	OP	1	VERY
Phosalone (Zolone)	Insecticide	OP	82	MODERATELY
Phosmet (Imidan)	Insecticide	OP	113	MODERATELY
Phosphine (Phostoxin)	Insecticide	FUM	11 (LC <sub>50</sub> )*	INHALATION HAZARD
Picloram (Tordon)	Herbicide	ML	8,200	SLIGHTLY
Piperonyl butoxide	Insecticide	ML	6,150	SLIGHTLY
Pirimicarb (Pirimor)	Insecticide	CB	147	MODERATELY
Prohexadione calcium	Growth regulator	ML	5,000+	SLIGHTLY
Propiconazole	Fungicide/wood preserv.	ON	1,211	SLIGHTLY
Pyrasulfotole	Herbicide	ON	2,000+	SLIGHTLY
Pyrazon	Herbicide	ON	2,500	SLIGHTLY
Pyrethrum (Pyrethrin)	Insecticide	ML	200	MODERATELY
Quinclorac	Herbicide	ML	2,190	SLIGHTLY
Quintozene (PCNB)	Fungicide	ON	1,650	SLIGHTLY
Resmethrin	Insecticide	PY	1,100	SLIGHTLY
Rotenone (Deritox)	Insecticide	ML	132	MODERATELY
Sethoxydim (Poast)	Herbicide	ML	2,700	SLIGHTLY
Silica aerogel (Drione)	Insecticide	IN	3,160	SLIGHTLY
Simazine	Herbicide	ON	5,000	SLIGHTLY
Sodium chlorate (Atlacide)	Herbicide	IN	1,200	SLIGHTLY
Sodium fluoride	Insecticide	IN	75	MODERATELY
Sodium pentachlorophenate	Fungicide/wood preserv.	OC	210	MODERATELY
Spirodiclofen (Envidor)	Insecticide	OC	2,000+	SLIGHTLY
Streptomycin	Fungicide	ML	9,000	SLIGHTLY
Strychnine	Rodenticide	ML	30	VERY
Sulfaquinoxalime	Rodenticide	ML	1,000	SLIGHTLY
Sulfosulfuron	Herbicide	ON	5,000+	SLIGHTLY
Sulfotep (Plantfume)	Insecticide	OP	5	INHALATION HAZARD

\* The toxicity of gases is measured as a lethal concentration (LC<sub>50</sub>).

**Table 4: Acute toxicities of pesticides (continued)**

Chemical name (Trade name)	Major use (Target pest)	Chemical family	Oral LD <sub>50</sub>	Acute toxicity rating
Sulfuryl fluoride	Insecticide	FUM	100	INHALATION HAZARD
TCMTB (Busan)	Fungicide/wood preserv.	ML	1,590	SLIGHTLY
Tebufenozide (Confirm)	Insecticide	ON	5,000+	SLIGHTLY
Terbacil (Sinbal)	Herbicide	ML	5,000+	SLIGHTLY
Terbufos (Counter)	Insecticide	OP	1.6	VERY
Tetrachlorvinphos	Insecticide	OP	1,000	SLIGHTLY
Tetramethrin	Insecticide	PY	1,010	SLIGHTLY
Thiabendazole (Mertect)	Fungicide	ML	3,100	SLIGHTLY
Thiophanate-methyl (Easout)	Fungicide	CB	7,500	SLIGHTLY
Thiram (Arasan, Arborgard)	Fungicide	CB	375	MODERATELY
Triallate (Avadex)	Herbicide	CB	675	SLIGHTLY
Trichlorfon (Dipterex, Neguvon)	Insecticide	OP	450	MODERATELY
Triclopyr (Garlon)	Herbicide	ML	713	MODERATELY
Trifluralin (Treflan)	Herbicide	ML	3,700	SLIGHTLY
Triforine (Funginex)	Fungicide	ML	6,000	SLIGHTLY
Warfarin	Rodenticide	AC	185	MODERATELY
Zinc naphthenate (Cuprinol)	Fungicide/wood preserv.	IN	4,920	SLIGHTLY
Zinc phosphide (Mouse Bait, Z-phos)	Rodenticide	ML	46	VERY
Zineb	Fungicide	CB	1,000	SLIGHTLY
Ziram	Fungicide	CB	1,400	SLIGHTLY
Zoxamide	Fungicide	ON	5,000+	SLIGHTLY

**Note**

Oral LD<sub>50</sub>s in Table 4 are based on information from the *Handbook for Pesticide Applicators and Dispensers*, B.C. Ministry of Environment (2005), and from the Pest Management Regulatory Agency of Health Canada.







**Table 5: Health effects of some major classes of pesticides**

Classes	Examples	Nature of toxic effect	Acute poisoning symptoms	Comments
<b>INSECTICIDES</b>				
Organophosphates (OP)	Azinphos-methyl Chlorpyrifos Coumaphos Diazinon Dichlorvos Malathion Methamidophos Sulfotep Terbufos	Can be absorbed through skin, stomach, and lungs. OPs interfere with cholinesterase—a body enzyme that is essential in the transmission of nerve impulses. Cholinesterase affected for up to 2–3 weeks.	<b>Mild:</b> headaches, weakness, blurred vision, excess perspiration, nausea, vomiting, excess salivation, feeling of constriction in throat. <b>Severe:</b> muscle twitching, constriction of pupils, bluish skin, convulsions, coma, death.	Some OPs such as methamidophos have caused chronic nerve damage. All OPs can cause cumulative acute effects if exposure is repeated day after day. A simple blood test can be used to check for cholinesterase interference by OPs.
Carbamates (CB)	Carbaryl Carbofuran Methomyl Pirimicarb	Almost identical to OPs, but cholinesterase is affected only for about 24 hrs.	Acute symptoms resemble those caused by OPs.	Repeated daily exposure does not cause cumulative effects.
Organochlorines (OC)	Dicofol Diflubenzuron Endosulfan Toxaphene	Can be absorbed through skin, lungs, or mouth. Brain stimulant leading to convulsions and lung failure.	Nausea, restlessness, tremors, muscular weakness convulsions, coma.	Often stored in fat where they may be inactive.





**Table 5: Health effects of some major classes of pesticides (continued)**

<b>Classes</b>	<b>Examples</b>	<b>Nature of toxic effect</b>	<b>Acute poisoning symptoms</b>	<b>Comments</b>
<b>FUNGICIDES</b> Carbamates, dithiocarbamates (CB)	<i>Carbamates</i> Thiophanate-methyl  <i>Dithiocarbamates</i> Ferbam Maneb Nabam Thiram Zineb	All are skin irritants. Do not inhibit cholinesterase like carbamate insecticides.  The dithiocarbamates can interfere with the ability of the body to handle alcohol.	Skin irritation  Vomiting may occur if there is exposure to both alcohol and dithiocarbamates.	Exposure to some may lead to skin allergy.  Some dithiocarbamates break down to produce ethylenethiourea (ETU). Possible carcinogenic and other chronic effects noted by Registry of Toxic Effects of Chemical Substances (RTECS).
Organochlorines (OC)	Captan Chlorophenates Pentachlorophenol	Skin irritants	Skin irritation	Some concerns in literature about chronic effects.
Nitrophenols (NP)	Dinocap	Chemical increases body activity and heat production.	Sensation of heat, flushed skin, thirst, rapid respiration. Also a skin irritant.	May cause skin allergy in rare cases. Repeated poisoning can lead to weight loss and insomnia.





**Table 5: Health effects of some major classes of pesticides (continued)**

Classes	Examples	Nature of toxic effect	Acute poisoning symptoms	Comments
<b>HERBICIDES</b>				
Phenoxy herbicides (PH)	2,4-D MCPA	Severe poisoning most likely to occur if taken by mouth.	Irritating to skin if swallowed; may cause abdominal pain, diarrhea, stiffness, irregular heartbeat.	2,4-D considered a possible carcinogen by IARC
Nitrophenols and benzonitriles (NP)	Bromoxynil loxynil	Same as for nitrophenol fungicides. <b>WARNING:</b> This is one of the most acutely toxic classes of herbicides.	Same as for nitrophenol fungicides.	Same as for nitrophenol fungicides.
Bipyridines (BP)	Paraquat Diquat	Extreme skin and membrane irritants. Severe poisoning usually due to ingestion. May also enter through lungs and mouth.	Nausea, vomiting diarrhea, jaundice. Bleeding from stomach or bowel. Failure to urinate.	<b>NO ANTIDOTE AVAILABLE</b> Do not give oxygen as a first aid measure. May cause long-term kidney, liver, and lung damage.
Organonitrogens (ON)	Atrazine Diuron Simazine	These ONs may produce irritation of skin. Severe poisoning only likely with ingestion.	On skin: eye, nose, throat, and skin irritation. If swallowed: lethargy, coma, convulsions.	May be formulated in emulsifiable concentrate (EC) with solvent such as xylene.
Inorganics (IN)	Sodium chlorate	This inorganic is a skin irritant. When taken by mouth, may produce kidney and liver damage, circulatory failure.	Vomiting, diarrhea, sweating, scanty urine, convulsions, coma.	Sodium chlorate is a powerful oxidizing agent. Can cause fire or burn on organic materials such as cotton clothing, leather boots, wooden shelving. Store and use carefully.





**Table 5: Health effects of some major classes of pesticides (continued)**

<b>Classes</b>	<b>Examples</b>	<b>Nature of toxic effect</b>	<b>Acute poisoning symptoms</b>	<b>Comments</b>
<b>RODENTICIDES</b> Anticoagulants (AC)	Bromodiolone Chlorophacinone Diphacinone Warfarin	Main route for severe poisoning is ingestion. Reduce clotting ability of the blood.	Bleeding from nose, gums, and into urine and stools. Possible skin bruising and bleeding of internal organs including brain.	Vitamin K is an antidote.
<b>FUMIGANTS (FUM)</b> Methyl bromide		Lungs the most important route of entry. Can also enter by skin and mouth.	Headache, dizziness, nausea, coughing, convulsions, coma. Also a severe skin irritant.	Gas detection equipment includes colourimetric tubes. Don't wear gloves, rings, etc. that can trap methyl bromide against the skin.
Phosphine (from aluminum phosphide and magnesium phosphide)		Extremely toxic by inhalation. A lung irritant and central nervous system depressant.	Coughing, headache, difficulty breathing. Higher levels can cause pulmonary edema. Not a skin irritant.	Gas detection equipment includes colourimetric tubes. Phosphine is flammable.
NOTE: Fumigants are generally extremely toxic and are primarily inhalation hazards. Toxic effects vary from one fumigant to the next. See Chapter 7 for more information on fumigants.				







# 5 Pesticide hazard evaluation

**This chapter includes the following sections:**

- Introduction
- Pesticide toxicity
- Amount of pesticide
- Pesticide formulation
- Amount of pesticide in the air
- Warning properties
- Persistence
- Mixing, loading, and application equipment







## Introduction

---

A first step in the safe use of a pesticide is to assess the **hazard** involved in the application process. It is the employer's responsibility to ensure that the proper hazard assessment has been done and the necessary controls have been put in place.

An applicator who knows the hazards is in a position to select the right personal protective equipment and the necessary safe work procedures.

Pesticide toxicity was discussed in Chapter 4. *Toxicity is not the same thing as a hazard.*

**TOXICITY:** The harm a particular pesticide can produce if it contacts or is taken into the body. Toxicity is a characteristic of the pesticide itself.

**HAZARD:** An estimate of the overall danger a worker faces when using a pesticide. Hazard depends not only on the toxicity of the pesticide but also on the likelihood that the worker may be exposed to the pesticide during use. The chance of exposure depends on a number of factors such as amount of pesticide used, strength of pesticide, warning properties, persistence, and type of application equipment. Hazard is a characteristic of the entire pesticide application process.

For example, a moderately toxic pesticide such as diazinon is likely more hazardous to workers if applied by a boom or air blast sprayer than a highly toxic pesticide such as brodifacoum when used as a bait to kill rodents.

Basic factors that affect the degree of hazard of a particular pesticide application are listed in Table 6. Workers who can answer the questions related to each factor are far more likely to be able to work safely with pesticides than workers who cannot.







**Table 6: Factors that determine the hazard of pesticide use**

<b>Hazard factor</b>	<b>Questions workers should ask</b>
Pesticide toxicity	What are the likely acute and chronic health effects from exposure to the pesticide? Is there a less toxic pesticide I can use?
Amount of pesticide	How much pesticide should I apply?
Pesticide formulation	How hazardous is the type of formulation I am using?
Amount of pesticide in the air	What levels of pesticide am I likely to breathe in the air?
Warning properties	Am I able to smell or sense the pesticide before it gets to levels in the air that could be dangerous?
Persistence	How long does the pesticide or any toxic by-product remain in the environment?
Equipment type and operation	How do the type of equipment and the ways of operating it affect the likelihood I may be exposed to pesticide?





## Pesticide toxicity

---

### ***What are the likely acute and chronic effects from exposure to the pesticide? Is there a less toxic pesticide I can use?***

Often, more than one pesticide is recommended for the control of a particular pest. The safety-conscious applicator will want to consider the relative toxicities of the different pesticides in deciding which product to use. Refer to Chapter 4 of this manual for information on pesticide toxicity.

#### **Note**

If a pesticide is designated as a carcinogen, sensitizer, or reproductive toxin in the Table of Exposure Limits for Chemical and Biological Substances, then the employer must replace it, where practicable, with a material that reduces the risk to workers. The Table can be accessed at [WorkSafeBC.com](http://WorkSafeBC.com).





## Amount of pesticide

---

### ***How much pesticide should I apply?***

The less pesticide applied by a worker, the less the hazard to that worker's health. The correct timing of a pesticide application and the technique used to apply it may be important in getting maximum results with a minimum amount of material.

In some cases, non-chemical methods may be available to deal with a particular pest problem.

**Integrated pest management** is a multi-strategy approach to pest control that includes the techniques of

- **Biological monitoring** of pest populations with devices such as colour-attractant traps, pheromone traps, beating trays, and sweep nets
- **Biological pest control** with insect predators, or with a variety of parasites such as bacteria, viruses, and fungi
- **Cultural (or administrative) pest control** measures such as crop rotation, moisture control, sanitation, and mow strips

Detailed advice on pesticide timing, dosage rates, and alternatives can be obtained from agencies such as the B.C. ministries of Environment, Agriculture, and Forests.





## Pesticide formulation

---

### *How hazardous is the type of formulation I am using?*

Two factors determine the hazard a formulation presents: the type of formulation, and the strength of its active ingredient.

### **Type of formulation**

Chapter 2 introduced the health and safety implications of pesticide formulations. In brief:

- Formulations contain not only active ingredients but also other materials called formulants, some of which may be toxic to people. Examples of toxic formulants include asbestos, toluene diisocyanate, formaldehyde, and phenol.
- Dusts, fogs, gas fumigants, and wettable powders (when dry) are easily inhaled.
- Many emulsifiable concentrates (ECs) are diluted with flammable materials such as xylene. Such materials can also cause health problems.
- Some wettable powders (WPs) may be mixed with diatomaceous earth (DE), which contains free silica. Free silica can cause scarring of lung tissue and has been linked to lung cancer.
- The persistence of a pesticide increases with the size of the particle containing the active ingredient. For example, granules are often long lasting.
- Wettable powders are more easily dislodged from plant surfaces than emulsifiable concentrates. In addition, WPs are also more likely to cause physical wear on application equipment than ECs.
- Encapsulated pesticides are likely to result in lower dust and vapour hazards during application. Encapsulated pesticides last longer in the environment than non-encapsulated varieties. Overheating of such pesticides may cause the capsules to rupture.





---

## **Strength of formulation**

Strength refers to the amount of active ingredient in the total pesticide formulation. The stronger the formulation, the more hazardous it is. The strength of formulations in commercial containers is given on the container label, immediately following the word "Guarantee." If, before application, the material in the container is diluted with a material such as water, the hazard is reduced accordingly.

Handling undiluted pesticides, such as during mixing and loading activities, can be even more hazardous to workers than the actual spraying. One study of worker exposure to azinphos-methyl in the Canadian tree fruit industry found that air levels of pesticide in the mixing area were four times higher than during spray operations.



## Amount of pesticide in the air

---

### **What levels of pesticide am I likely to breathe in the air?**

Four basic factors affect pesticide levels (concentrations) in the air: type of formulation, spray particle size, wind speed, and pesticide evaporation.

- **Type of formulation**

Dusts, dry wettable powders, and gas fumigants are more likely to remain in the air after application than other types of formulations. Encapsulated pesticides generally permit less release in the air than non-encapsulated varieties.

- **Size of spray particle**

The ability of a spray mist to drift depends to a great extent on the size of the spray particles. As shown in Table 7, very fine particles can drift a kilometre or more in fairly still air, whereas coarser sprays can be expected to settle out within 10–15 metres of the point of application. This is why high-pressure, fine insecticidal sprays present a far higher drift hazard than coarse herbicide applications.

- **Wind speed**

Wind speed drastically affects spray drift. A study showed that in an 8 km/h (5 mph) wind, the drift of an insecticide from a boom sprayer was about 30 metres. But when the wind speed was doubled to 16 km/h, the drift was about 10 times farther. This is why it is recommended that spraying not be done in wind speeds of more than 8 km/h.

### **Table 7: Drift potential of pesticide particles**

(Source: *Twelfth Annual Report of the Canada Committee on Agricultural Meteorology to the Canadian Agricultural Coordinating Committee*, Ottawa, Ontario, January 27–28, 1971 [with figures converted to metric])

<b>Particle diameter in microns*</b>	<b>Particle type</b>	<b>Distance of drift carried by a 5 km/h wind while falling from a height of 3 metres</b>
400	Coarse spray	2.7 m
150	Medium spray	7 m
100	Fine spray	15 m
50	Very fine spray	54 m
20	Fogs	367 m
10	Dusts and aerosols	1,345 m

\* 1 micron = one-millionth of a metre



### Note

Check the pesticide material safety data sheet (MSDS) for information on vapour pressure. The sample MSDS in Chapter 2 of this manual shows vapour pressure listed under Section 3 (Physical Data).

- **Pesticide evaporation**

Many pesticides are applied as liquids. Liquid pesticides (and, to a limited extent, solids) evaporate when exposed to the air. During the evaporation process, tiny particles (molecules) of liquid escape from the surface and mix with the air to form a **vapour**.

Vapours are not the same as spray mists. **Mists** are composed of *visible* liquid droplets produced during the spray process and are usually present for only a short period following application. **Vapours** are made up of *invisible* molecules and can be present long after a pesticide application or in other situations where liquids are exposed to the air (e.g., when a pesticide container is left open, or in the case of a pesticide spill). It is important for those working with pesticides to protect themselves against vapours as well as mists.

- **Vapour pressure**

The amount of vapour in the air from a liquid (or solid) can be measured with instruments similar to barometers. These devices record the pressure produced by the vapour, or what is called *vapour pressure*. Just like barometers, these instruments give readings in inches or millimetres (mm) of mercury.

Relative vapour pressure ratings of some common pesticides are provided in Table 8. Those with VERY HIGH vapour pressures (above 100 mm of mercury) are generally used as structural fumigants. These pesticides have pressures that are sometimes greater than sea level atmospheric pressure (which is 760 mm). For example, methyl bromide has a vapour pressure of about 1,900 mm of mercury.

Many of the HIGH vapour pressure pesticides (between 10 mm and 100 mm) are soil fumigants.

INTERMEDIATE pesticides (in the range of .01 to 10 mm) include some of the more easily evaporating insecticides such as dichlorvos and carbaryl.

LOW vapour pressure materials (from .01 down to .0001 mm of mercury) include a variety of pesticides, such as some of the organophosphate insecticides.

Those with VERY LOW vapour pressure (below .0001 mm of mercury) include many of the herbicides, fungicides, and organochlorine insecticides.





#### - Vapour hazard

The hazard of a vapour to workers increases as the vapour pressure rises. However, a pesticide with an intermediate or low vapour pressure can still be a significant inhalation hazard.

For example, dichlorvos, which is in the intermediate vapour pressure range, is extremely toxic. Because of its high toxicity, even small amounts in the air are hazardous.

In some situations, a pesticide liquid or mist may fill the air around it with the maximum amount of vapour possible. This could occur in enclosed conditions such as a storage shed in which pesticide has spilled, or where quantities of pesticide are applied inside a space such as a greenhouse. Based on the vapour pressure of a pesticide, it is possible to determine whether the resulting atmosphere would contain vapour concentrations above the safe limits established by WorkSafeBC.

Table 8 shows the relative vapour pressures of a variety of pesticides. Calculations show that the high vapour pressure gas and soil fumigants listed in the table are likely to produce exposures above exposure limits in enclosed conditions. In addition, some lower vapour pressure, high toxicity carbamate and organophosphate pesticides may be above limits, too.

And it is important to remember that as air temperature increases, vapour hazards will increase. **The vapours from many pesticides increase three to four times for each 10°C increase in temperature.** This is one reason why pesticides should be stored away from sunlight, and why it is typically recommended that pesticides not be applied when air temperatures are above 30°C.

#### Defining vapour pressure

“The vapour pressure is the pressure at which a liquid and its vapour are in equilibrium at a given temperature. The vapour is said to be “pushing” against the atmosphere. In other words, the higher the vapour pressure the faster a liquid evaporates. When the vapour pressure reaches the atmospheric pressure, the liquid is at its boiling point.”

Source: Fred Scaffidi,  
*Assessing Hazards:  
Importance of Vapour  
Pressure*, Transport  
Canada







**Table 8: Relative vapour pressures of pesticides**

<b>Relative vapour pressure</b>	<b>Pesticide name</b>
VERY HIGH Above 100 millimetres of mercury (mmHg)	Acrolein Hydrogen cyanide Methyl bromide Phosphine Sulfuryl fluoride
HIGH 10 to 100 mmHg	Dichloropropenes Dimethoate Formaldehyde
INTERMEDIATE 0.01 to 10 mmHg	Carbaryl 2,4-D Dichlorvos
LOW 0.0001 to 0.01 mmHg	Diazinon Methamidophos Sulfotep Triallate
VERY LOW Below 0.0001 mmHg	Acephate Atrazine Azinphos-methyl Captan Carbofuran Chlorpyrifos 2,4-D amine Diquat Malathion Paraquat Pentachlorophenol Picloram Warfarin Zineb



## Warning properties

---

### ***Am I able to smell or sense the pesticide before it gets to levels in the air that could be dangerous?***

Many pesticides that evaporate into the air provide a warning of their presence by their smell or by producing irritation of the eyes, nose, or throat.

Pesticide odours can vary somewhat with the chemical class of pesticide. As shown in Table 9, organophosphates tend to have strong odours variously described as “garlic-like,” “sulfur-like,” etc. Among the carbamates, the insecticides are often almost odourless, whereas a number of the herbicides are sweet smelling. Some but not all organochlorines have mild odours.

Many fumigants have distinctive odours, but some, such as methyl bromide and sulfur dioxide, are basically odourless unless mixed with an odourant such as chloropicrin.

The odour of a given pesticide can only be detected when it gets to a level (or concentration) in the air at which a person would notice the smell. This level is called the *odour threshold*.

Pesticides with **good warning properties** are noticed by the senses at a level in the air well *below* the level of chemical that can cause ill health effects.

The warning properties of many pesticides may be rated GOOD, FAIR, or POOR by comparing odour thresholds with WorkSafeBC’s eight-hour exposure limits, as follows:

Warning properties	
<b>GOOD</b>	Odour threshold is less than one-tenth of the exposure limit.
<b>FAIR</b>	Odour threshold is between one-tenth of the exposure limit and three times above it.*
<b>POOR</b>	Substance is odourless, or the odour threshold is at least three times above the exposure limit.

\* The rating system provided here is meant only as an approximate guide. If, for example, a particular pesticide can cause serious health effects at any level above the exposure limit, then the warning properties of that pesticide should be considered to be POOR if the odour threshold of that pesticide is higher than the limit.

To assess warning properties, check the pesticide MSDS for odour and odour threshold information. (In the sample MSDS provided in Chapter 2 of this manual, this information would be reported under Section 3, Physical Data.) Then compare the odour threshold on the MSDS, if one is provided, with the



exposure limit for the substance. WorkSafeBC provides exposure limits for many pesticides in the Table of Exposure Limits for Chemical and Biological Substances, which can be accessed at [WorkSafeBC.com](http://WorkSafeBC.com).

As an example, methyl bromide has poor warning properties because it is basically odourless until it reaches 500 ppm, but its exposure limit is 1 ppm. On the other hand, dichloropropene, which has an odour threshold of about 1 ppm and an exposure limit of 1 ppm, has fair warning properties.

**Table 9: Pesticide odours**

**Note**

The odour of a pesticide can vary with its formulation and the presence of impurities. For example, any emulsifiable concentrate may have a sweet, aromatic odour due to the presence of the carrier, xylene. Also, people can have different responses to particular odours. For these reasons, information on odours and odour thresholds should be treated with caution.

Chemical name and class	Odour
<b>ORGANOPHOSPHATES</b>	
Azinphos-methyl (Guthion)	Dry sweet, nauseating
Chlorpyrifos (Dursban)	Sulfur-like (mercaptan) smell
Diazinon	Faint, fruity, ester-like
Dichlorvos	Mild aromatic
Dimethoate (Cygon)	Sulfur-like (mercaptan) smell
Malathion	Garlic-like
Phosalone (Zolone)	Garlic-like
<b>CARBAMATES</b>	
Many insecticides (e.g., carbaryl, carbofuran)	Odourless
Methomyl	Slight sulfur-like
Thiocarbamate herbicides (e.g., EPTC, triallate)	Aromatic
<b>ORGANOCHLORINES</b>	
Captan	Musty
Endosulfan	Faint, sulfur-like
Folpet	Faintly pungent and sulfur-like
<b>FUMIGANTS</b>	
Chloropicrin	Acrid, intensely irritating
Dichloropropene	Sharp, sweet, irritating
Ethylene oxide	Irritating, ether-like
Formaldehyde	Pungent, irritating
Hydrogen cyanide	Bitter almond
Methyl bromide	Irritating if mixed with chloropicrin; otherwise, almost odourless
Phosphine	Fish- or garlic-like
Sulfuryl fluoride	Irritating if mixed with chloropicrin; otherwise, odourless





## Persistence

---

### ***How long does the pesticide or any toxic by-product remain in the environment?***

Persistence is the ability of a pesticide to maintain its toxic properties over time. Persistence may be a health and safety concern when workers, children, or the general public enter areas such as fields, greenhouses, parks, and offices that have been treated with pesticides.

The initial period after application of a pesticide can be particularly hazardous to a person who enters the area because of the presence of

- Pesticide vapours in the air
- Surfaces wetted with pesticide
- Dislodgeable pesticide residues on vegetation

However, the pesticide may continue to be a hazard after that period because of ongoing persistence.

Persistence of pesticides has been evaluated in water, in soil, and on leaf surfaces. In water, persistence may be an issue related to fish habitats and the safety of public drinking water. Persistence in soil tends to be a health issue for young children who may play in the soil, and to workers who may be exposed to pesticide-laden dusts. Residues on leaves, furniture, and other items present health concerns to field and office workers who may come into direct contact with treated surfaces. The following factors can affect the rate of decomposition of pesticides after they are applied:

### **Chemical family of pesticide**

Organophosphates and carbamates are often far less persistent than organochlorines. For example, in Table 10, almost all of the short-lived (less than two weeks) pesticides are organophosphates. Half of the highly persistent (more than one month) pesticides are organochlorines. This fact may help explain why some organochlorines are no longer permitted for use in Canada.

Inorganic pesticides that contain metals such as arsenic, mercury, and copper are generally very persistent. Arsenic pesticides have been shown to last for 10 years in soil.

### **Type of formulation**

Larger physical aggregates such as granules and pellets will physically resist the effects of the environment longer than finer particles such as dusts and wettable powders.





Wettable powders can leave residues that are coarser and predictably more persistent than residues of emulsifiable concentrates.

Wettable powders are more easily dislodged from leaf surfaces than are emulsifiable concentrates. For this reason, wettable powders can present a greater field re-entry hazard.

### Strength of pesticide

The higher the strength or concentration of a pesticide, the longer the chemical will persist in the environment.

Studies in the State of Washington have shown that even for non-persistent pesticides like azinphos-methyl (Guthion) and parathion, if liquid concentrates are spilled in soil, high residue levels can persist for years. In one study, four years after a spill of 18% azinphos-methyl emulsifiable concentrate, soil levels of the pesticide were still one percent.

The need to clean up and remove soil contaminated with concentrates is illustrated by a case in which a child almost died after ingesting some soil contaminated with one-percent parathion, a pesticide with a toxicity very similar to azinphos-methyl.

### Ability of pesticides to form toxic by-products

Some pesticides have been found to produce toxic decay products that may contribute to the length of period of toxicity of the pesticide. Examples are provided below.

Pesticide	Toxic by-product	Comments
<i>Organophosphates that have sulfur attached to phosphorus in the chemical formula.</i> For example, "thion" pesticides such as ethion, fensulfothion, fenthion, Guthion, and other OPs such as chlorpyrifos, diazinon, and dimethoate.	"Oxons" in which the sulfur in the parent pesticide is replaced by oxygen from the air. Oxons may be 10 times more toxic than the parent pesticide.	Oxons tend to form under sunny conditions with little rainfall or dew.
<i>Dithiocarbamates</i> such as maneb, nabam, and zineb.	Ethylene thiourea (ETU).	ETU can cause chronic health problems.
<i>Carbamates</i> (with secondary amine structure) such as propoxur and triforine.	Nitroso compounds.	Nitroso compounds may develop on contact with nitrogen dioxide (a pollutant from automobile emissions and cigarette smoke). Nitroso compounds persist only in dark enclosures and in acidic soils.





---

## **Weather conditions**

Wind, moisture, and increased temperature tend to increase the rate of decomposition of most pesticides.

## **Soil conditions**

### **Organic content**

Pesticides tend to decompose faster in soils with high organic content than those without.

### **Clay content**

Bipyridines like diquat and paraquat bind quickly to clay and become less hazardous.

### **Sand and gravel content**

These materials do not contribute to pesticide decomposition; however, they do permit easy movement of pesticide in soil water. This can be hazardous if sources of drinking water are nearby.

### **Temperature**

Higher temperatures tend to produce higher rates of decomposition of pesticides.

### **Acidity/alkalinity**

Organophosphates and carbamates tend to decompose most easily in alkaline soils.

Tables 10, 11, and 12 provide information on persistence periods for a number of

- Insecticides on plants
- Herbicides in soil
- Fungicides in soil

All estimates should be considered approximate because of the many effects of environmental factors on pesticide decomposition rates.





**Table 10: Persistence of some insecticides on plants<sup>1</sup>**

Less than 2 weeks	2 weeks–1 month	More than one month
Acephate	Carbaryl	Aldrin <sup>2</sup>
Azinphos-methyl	Carbofuran	Chlordane <sup>2</sup>
Cyhexatin	Chlorpyrifos	Ethion
Diazinon	Endosulfan	Fensulfothion
Mevinphos	Fenthion	Heptachlor <sup>2</sup>
Pyrethrin		Phosmet
Sulfotep		Toxaphene
Trichlorfon		

Sources include: *Metabolism of Pesticides*, U.S. Department of the Interior (1980); *Handbook for Pesticide Applicators and Pesticide Dispensers*, B.C. Ministry of Environment (1980).

1 Persistence is evaluated as the capability to provide residual action against insects.

2 No longer registered for use.

**Table 11: Persistence of herbicides in soil<sup>1</sup>**

1 month or less	1–3 months	3–12 months <sup>2</sup>	Over 12 months <sup>3</sup>
Acrolein	Bentazon	Alachlor	Arsenic
Amitrole	Butachlor	Atrazine	Borate
Barban	Butylate	Bromoxynil	Bromacil
Cacodylic acid	Chloramben	Dicamba	Chlorate
Chloroxuron	Chlorpropham	Dichlobenil	Diquat <sup>4</sup>
Dalapon	Cycloate	Diuron	Paraquat <sup>4</sup>
2,4-D	Diallate	Fenuron	Picloram
2,4-DB	2,4-DEP	Isopropalin	Tebuthiuron
Endothall	Diphenamid	Linuron	Terbacil
Fluorodifen	EPTC	Metabromuron	
Glyphosate	Mecoprop	Metribuzin	
Metham	Naptalam	Monolinuron	
Methyl Bromide	Pebulate	Monuron	
Molinate	Pentachlorophenol	Prometryne	
Phenmedipham	Propachlor	Pronamide	
Propanil	Pyrazon	Simazine	
Propham	Triallate	Trifluralin	

Sources include: *Biodegradation of Pesticides*, Matsamura and Murti (1982); *Metabolism of Pesticides*, U.S. Dept. of Interior (1980); *Environmental Fates and Impacts of Major Forest Use Pesticides*, EPA (1981).

1 Time estimates are approximate and will vary somewhat with various environmental factors. Estimates apply to moist, fertile soils under field conditions in moderate summer temperatures.

2 At higher rates of application, some of these chemicals may persist for more than 12 months.

3 At lower rates of application, some of these chemicals may persist for less than 12 months.

4 Although this chemical may remain unchanged for a long time, it is absorbed so tightly to many soils that it may become biologically inactive within a short period.





**Table 12: Persistence of fungicides in soil**

<b>Fungicide</b>	<b>Half-life* (days)</b>	<b>Comments</b>
Captan	3–65 or more	Decomposes rapidly in moist conditions. More persistent in dry, acidic soils.
Chloroneb	30–90	Application rate: 2.25 kg/ha.
Chlorothalonil	Long half-life	Little breakdown noted on plant leaves.
Maneb	32–56	
Thiram	More than 40	Not detectable after 40 days at application rates of 250 ppm. More persistent at higher concentrations.

Sources include: *Biodegradation of Pesticides*, Matsumara and Murti (1982); *Metabolism of Pesticides*, U.S. Dept. of Interior (1980); *Pesticides Studies in Man*, Hayes (1982).

\* The half-life is the time taken for the level of fungicide to be reduced to half of its original concentration. It takes about three half-lives to reduce the amount of fungicide to one-tenth of original levels.







## Mixing, loading, and application equipment

---

### ***How do the type of equipment and the ways of operating it affect the likelihood I may be exposed to pesticide?***

Mixing, loading, and application equipment is available in a wide range of designs. Design differences may affect not only performance capabilities but also the hazard involved with equipment use.

### **Mixing and loading systems**

Despite what one might think, mixing and loading a pesticide may be more hazardous than applying it.

More than one-third of the pesticide illnesses reported by mixers, loaders, and applicators in California agriculture over a five-year period occurred among workers who only mixed and loaded pesticides.

Open mixing and loading systems are more hazardous than closed systems.

Open systems include those where the operator pours pesticide into the receiving container, or where this is done mechanically from one open container to another, as shown in Figure 4.

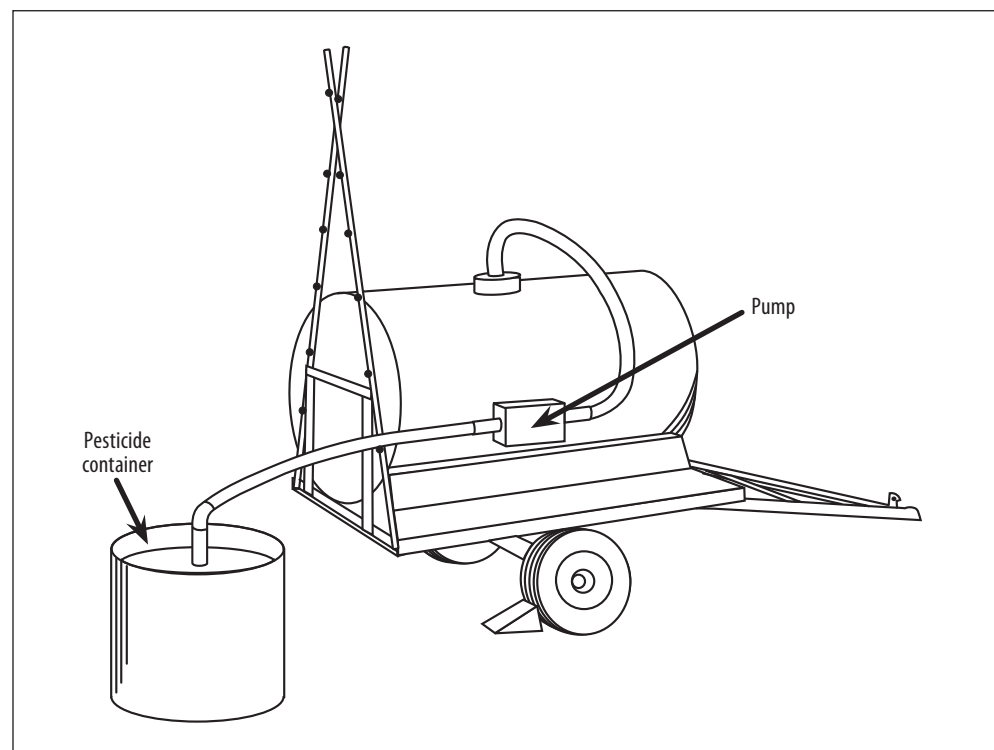

**Figure 4: Open liquid transfer system**





A closed system is a device and procedure for transferring a pesticide from the container in which it came to a closed mixing tank in a manner that does not expose the operator to the pesticide.

A diagram of a closed system is shown in Figure 5. Components include:

- **Probe**  
A device of plastic or steel that is inserted through a liquid-tight opening in the shipping container. The probe may feature a seal-cutting knife edge and usually consists of two tubes, one inside the other. One tube is used for rinsing, and the other is used for removal of pesticide from the container. The probe head features a rinse-water inlet.
- **Metering device**  
Sight gauges, calibrated probes, or in-line meters may be used for metering the desired amount of concentrate into the mix tank.
- **Hoses and couplings**  
Hoses and couplings must resist corrosive effects of concentrates and any pressure buildup in the system.
- **Pump**  
May be positive pressure or vacuum system.

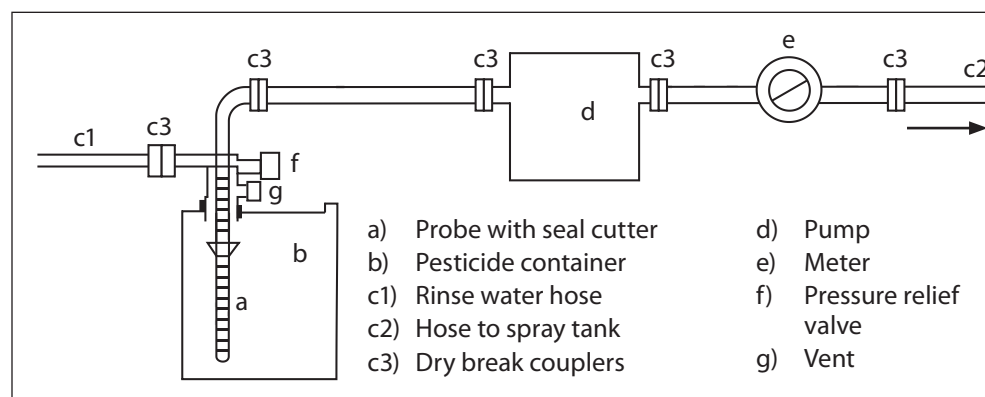

**Figure 5: Closed mixing and loading system**

The American Society for Testing and Materials has recommended the following features in a well-designed closed system:

- **Design simplicity**  
Preferred designs are simple, easily operated, and require a minimum number of steps for operation.
- **Probe design and materials**  
Difficulties with plastic probes have been reported. Some pesticides were found to attack solder on stainless steel probes. A promising design concept permits the probe head to be uncoupled from the probe tube.





- **Meter durability and sensitivity**  
Some metering devices, such as plastic in-line meters and probe calibration markings, tend to deteriorate. It is important to purchase a meter capable of measuring small quantities if small quantities are used.
- **Hoses and couplings**  
No-drip, quick-coupling connectors are recommended. Ensure that hoses, seals, and gaskets resist chemical corrosion.
- **Pumps**  
Vacuum pumps are considered to be safer and easier to operate than positive-pressure pumps.

In addition to concerns with mixing procedures, applicators must be aware of hazards associated with the use of application equipment.

In order to safely use and maintain equipment, examine each piece in order to locate **hazard points** or **critical parts**. These components may have a particular tendency to wear out, and they can cause operator exposure to pesticides in the event of malfunction. Once hazard points are located, the operator is in a position to set up an inspection and maintenance program.

Some hazard points are identified for the following types of solid, liquid, and gaseous pesticide application equipment:

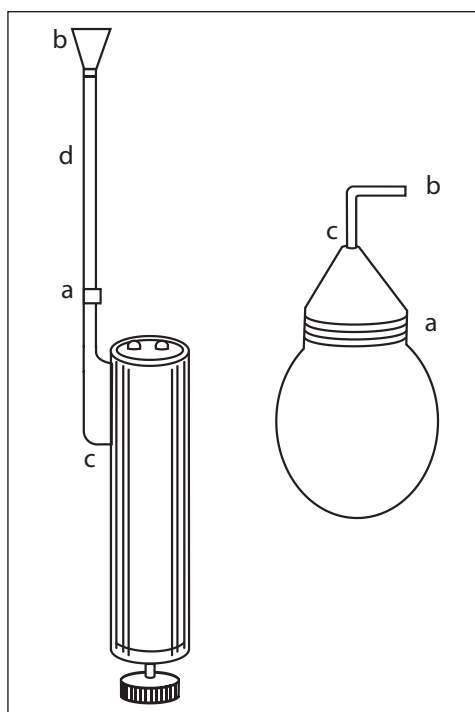

**Figure 6: Dusters**

### **Dusters**

Dusters are designed to blow fine particles of pesticide dusts onto a target surface.

Because dusts drift easily, homemade dusters made from perforated cloth, coffee cans, peppershakers, etc. are *not recommended*.

Professional dusting equipment is preferred. Bulb- and plunger-style dusters are shown in Figure 6.

### **Hazard points**

- Connections between parts**  
Threaded or clamped connections tend to leak far less dust than pressure-fit connections.
- Nozzle tip**  
Nozzle may become clogged, or in the case of light metal nozzles, misshaped to prevent proper application of dust. Back pressure in case of blockage may create a hazard.





c) **Point of attachment of delivery tube to duster body**

If the tube is inflexible, cracking at the point of attachment may occur.

d) **Delivery tube**

Seamless tubing is better than tubing with a folded seam.

## Granule applicators

These units employ positive metering systems that dispense by volume. Rate of application is controlled by the speed of a feed wheel and of the opening of a metering gate. Granules may be broadcast to soil with a whirling plate or applied in bands with gravity feed outlets or injector tubes.

Figure 7 shows an example of a multiple gravity feed band applicator.

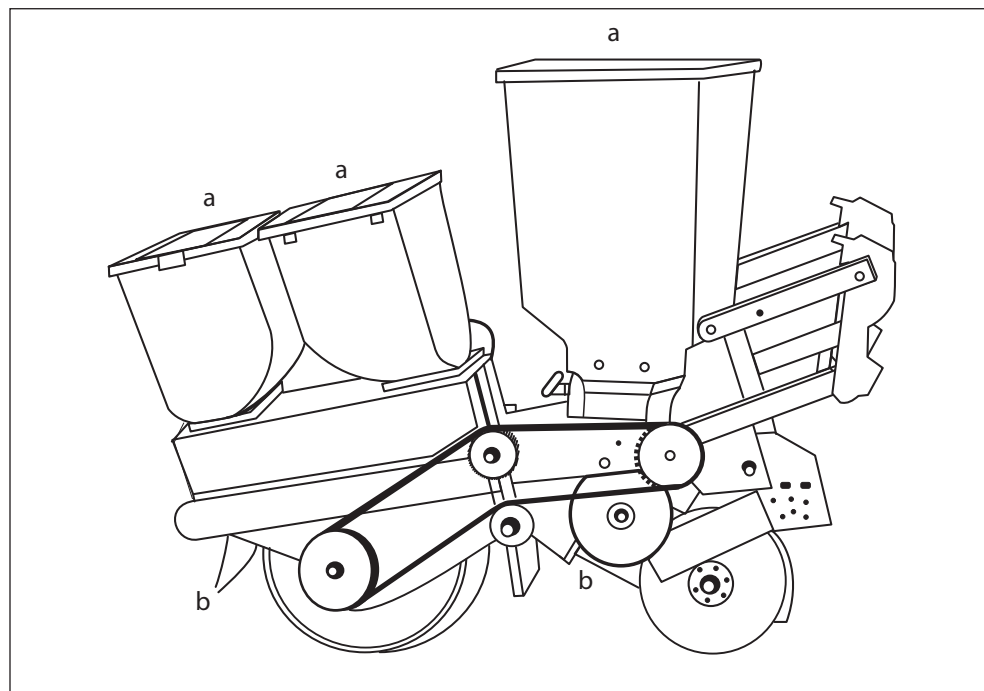

**Figure 7: Granule applicator**

### Hazard points

a) **Lids**

Lids reduce dust emissions and keep out moisture that may cause granule crust. Lids should be kept in good working order.

b) **Discharge points**

Likelihood of dust drift from the discharge device increases in the order: injector tubes, gravity feed outlets, and whirl plates.





---

## Hand sprayers

Hand-held sprayers, such as the one shown in Figure 8, can pose a number of hazards.

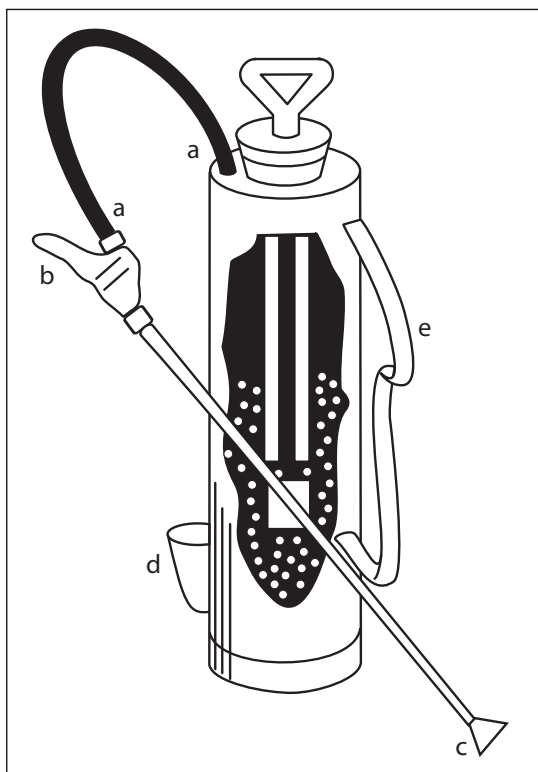

Figure 8: Hand sprayer

### Hazard points

- a) **Hose flex points**  
Cracks in hoses tend to develop at these points.
- b) **Trigger assembly**  
Leaks may develop around inadequately maintained seals.
- c) **Nozzle assembly**  
If the unit is provided with variable nozzle assembly with multiple nozzle openings, a safety design feature is a nozzle identification code on the side of the assembly. Such a code lets the operator select the nozzle opening without looking directly at nozzle orifices.
- d) **Gun mount**  
A safety feature that permits the applicator to affix the gun to the side of the tank when the gun is not in use.
- e) **Support strap**  
It is unsafe for the support strap to be made of material that will absorb chemicals.

## Backpack sprayers

These units, as shown in Figure 9, are carried on the back and permit a larger quantity of liquid to be carried than do hand sprayers.

A hand crank is employed to generate pressure inside an inverted column within the storage tank. The whole tank is not under pressure.

Backpack units are more hazardous than hand-held varieties because of the possibility of body drench if storage tank contents are spilled.



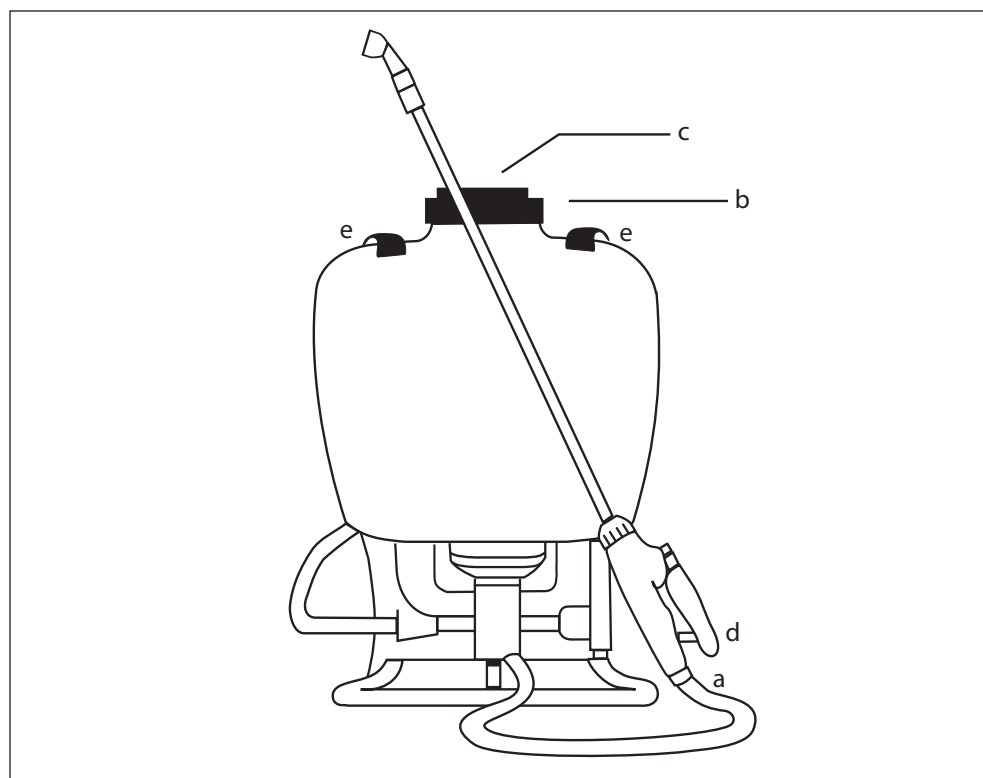

**Figure 9: Backpack sprayer**

### **Hazard points**

- a) **Delivery line connections**  
These may come loose due to frequent flexion and use in rugged terrain.
- b) **Cap**  
Either screw-on or plug-insert models are available, and they are often made of plastic. Sunlight and some chemicals can cause deterioration of plastic materials.
- c) **Air bleed hole**  
Designs without baffles or check valves are more hazardous than those that have such safety features.
- d) **Trigger assembly**  
Connections at the trigger assembly may leak due to inadequate tightening or faulty gaskets.
- e) **Support straps**  
These must be capable of supporting the weight of the unit. Absorbent straps are hazardous.





---

## Hydraulic spray units

Unlike compressed air devices, hydraulic spray units draw liquid pesticides directly through a power-driven pump, delivery hoses, and application nozzles. Hydraulic spray units are generally meant for high-volume, high-pressure applications in agriculture and weed-control operations.

There are three types of hydraulic spray units that differ according to the arrangement of application nozzles.

### *Hand spray gun*

Delivery hose leads to a trigger-operated gun with one or more nozzles. Hand spray guns are often used in municipal spray programs.

### *Boom spray unit*

Delivery hose leads to a boom with multiple nozzles. Boom may be horizontal for row and field crops, or in a tower arrangement for bush crops.

### *Air blast sprayer*

Delivery hose leads to nozzles arranged so that liquid is ejected into a high-velocity air stream. Air blast sprayers are used primarily in the tree fruit industry.

Hydraulic units of all types share a number of common design features, many of which should be considered as hazard points. Figure 10 provides a schematic outline of a typical hydraulic sprayer unit.



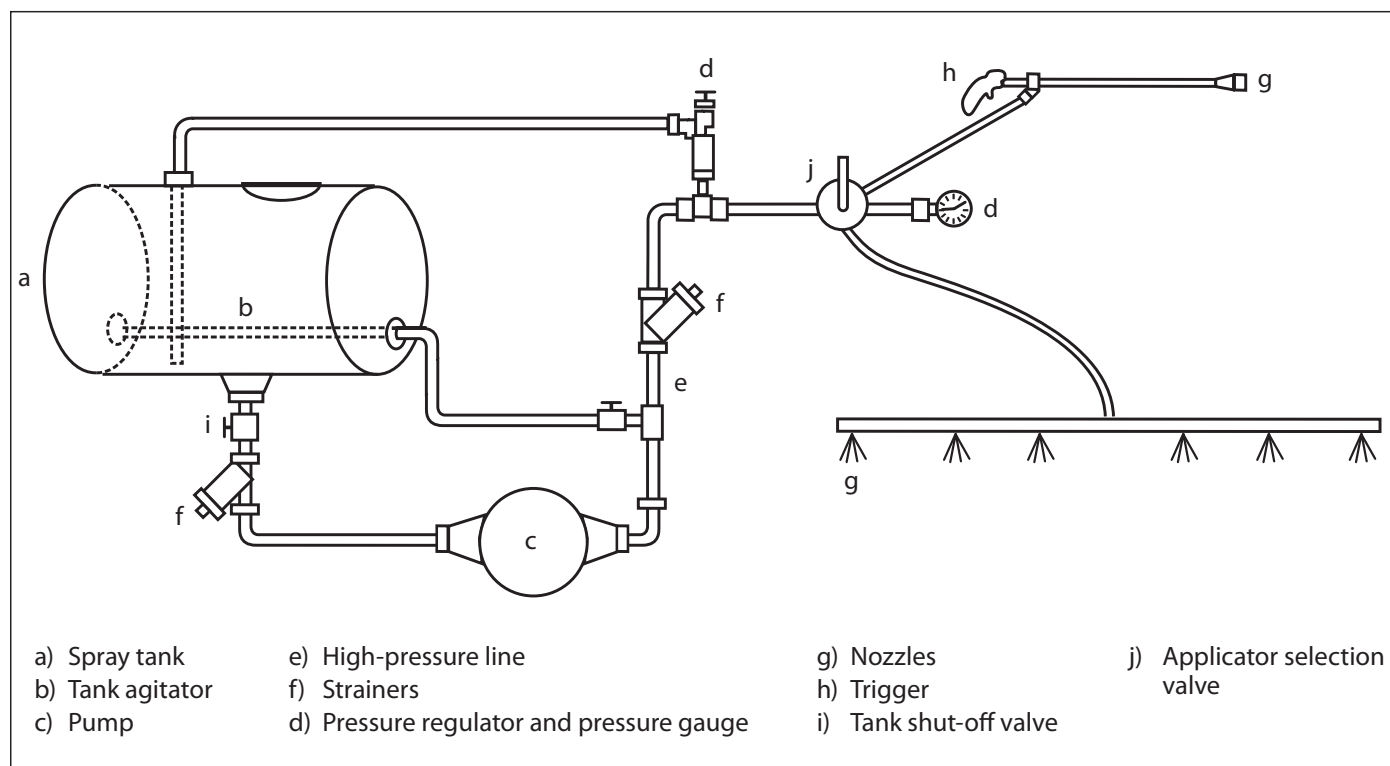

Figure 10: Hydraulic sprayer

### Hazard points

#### a) Spray tank

Tanks should be made of corrosion-resistant material. Safe design features include

- A large opening (at least 30 cm in diameter) with a filter screen for easy filling and cleaning
- A drain plug located so that the entire tank can be drained
- Rounded inside corners and edges for easy cleaning

The unit should also have a sight gauge for easy viewing. Check valves on the gauge will prevent tank drainage if the gauge breaks. If the pesticide formulation is highly coloured, a cork float in the gauge may make the gauge easier to read.







Spray tank component materials	
The following materials have been used in the construction of spray tanks and other components, such as pipes:	
Material	Comments
Mild or galvanized steel	May be corroded by acidic formulations and pesticides such as Bordeaux mixture, carbo-phenothion, chlorfenvinphos, 2,4-D, difenzoquat, endosulfan, mevinphos, paraquat, and phosphamidon.
Aluminum	Corroded by a number of pesticides including difenzoquat and paraquat.
Polyethylene	Generally resists chemical corrosion. May deteriorate if left in sunlight. Some plastics may deteriorate in presence of pesticides. Leaks may not be repairable.
Fibreglass	Resistant to corrosive effects of many chemicals. Repair kits are available.
Stainless steel or baked-on enamel	Generally corrosion resistant. Baked-on enamel may be chipped if struck with a sharp blow.

b) **Tank agitators**

Adequate agitation helps ensure the even application of pesticide and the safety of field workers who may later work in the treated area.

- **For emulsions**, the bypass line from the regulator valve may provide enough agitation. In the booklet *Field Sprayers*, Agriculture Canada has recommended that the return flow should not be less than 10 percent of the output (or less than 2.25 litres per minute) when the sprayer is operating. Flow should be directed towards the bottom of the tank.
- **For wettable powders**, additional hydraulic or mechanical agitation is necessary.

Hydraulic agitation employs a return flow of liquid through an agitator line on the high-pressure side of the pump to jet nozzles or a sparge pipe at the bottom of the spray tank. If operated correctly, a hydraulic agitation system may provide sufficient agitation for wettable powders. Agriculture Canada has recommended 3–6 litres per minute of hydraulic agitation per 100 litres of tank contents.

Mechanical agitation that employs a rotating propeller or other similar device is a preferred means of agitating wettable powders.





c) **Pumps**

Pumps vary a great deal in capacity, operating pressure, resistance to wear, and ease of repair. When selecting a pump, allow 25 percent reduction in capacity due to wear. Pumps must meet additional volume demands if hydraulic agitation is used.

d) **Pressure regulator and pressure gauge**

The regulator may be either a relief valve or an unloader design. For safe operation, it should be matched to the pressure and volume flow characteristics of the application equipment.

Gauges, on the output side of the pump, are one of the most important safety features on the spray unit. Dampened units usually are longer lasting than undampened designs. An indication of malfunction is unexpected fluctuations in pressure readings.

e) **Pressure lines**

Plumbing includes pipes and couplings. Hose test pressures should be two times normal operating pressures. Special high-pressure hoses made from materials such as PVC and steel braid are available. Clamps must be able to withstand the required pressures. Simple screw designs may not be sufficient in high-pressure applications, and hammer clamps may be necessary.

Plumbing materials should be corrosion resistant. It is recommended to shield the operator from high-pressure hoses with deflector shields, and to shield hoses from sources of damage (for example, when hoses are run along the undercarriage of the applicator units).

Safety features on hydraulic applicators include shut-off devices at the discharge ends of hoses and pipes leading from the mixing tank.

f) **Strainers**

Strainers are valuable features to reduce unit deterioration. They are generally provided at three locations:

- Suction strainers between the tank and pump
- Pressure line strainers between the pump and nozzle assembly
- Nozzle strainers mounted on each nozzle

g) **Nozzles**

Nozzles should be selected for spray type (solid stream, flat, cone), material, angle of spray, and rate of application.

Some nozzles are more hazardous than others. The drift potential of nozzles varies according to spray type and increases in the following order: solid stream, flat, and cone.

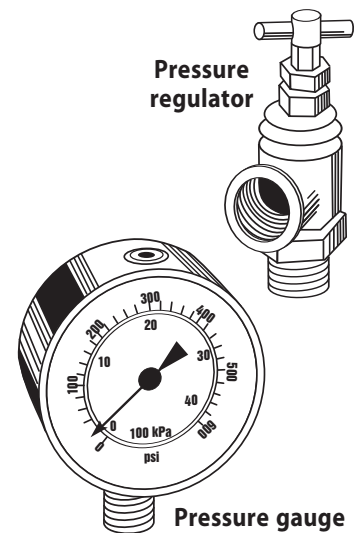



The first two numbers stamped on the nozzle tip indicate the angle of spray discharge. Typical angles are 65, 73, and 85 degrees. Generally, the wider the angle, the greater the possibility of drift.

Nozzle material is a major determinant of resistance to wear. Tungsten carbide and stainless steel tips are more resistant than those made of plastic or brass.

A number of nozzle design concepts have been developed that can help reduce the hazard to the applicator. These include

– ***Anti-drip nozzles***

These are designed to eliminate all drip when pressure to the boom is shut off. Two anti-drip designs include

- The nozzle strainer check valve
- The diaphragm check valve

– ***Anti-drift nozzles***

These may help reduce drift when operated under the conditions specified by the manufacturer.

– ***Quick-release nozzles***

These are designed for quick nozzle changes and may be helpful to applicators who must change nozzles regularly.

h) **Triggers**

Where the hydraulic application unit employs a hand spray gun, the trigger assembly itself is a hazard point.

Safety problems that may develop with triggers include accidental discharge, valve leakage onto the operator, and tendinitis from repeated trigger use. Specific safety features can help deal with such problems.

Possible safety problems	Good safety features
Accidental opening by bumping trigger	<ul style="list-style-type: none"> <li>• Trigger guard</li> <li>• Adequate spring force against trigger</li> </ul>
Leakage from trigger valve onto operator	<ul style="list-style-type: none"> <li>• Well-designed and maintained seals</li> </ul>
Tendinitis from squeezing trigger	<ul style="list-style-type: none"> <li>• Over-centre action on trigger</li> <li>• Comfortably shaped handle and trigger</li> </ul>

i, j) **Shut-off and selector valves**

Ensure that valves function properly and do not leak.





---

## Equipment used to pull sprayers

Many boom and air blast units are designed to be drawn by tractors. Hazard points on such vehicles include exposed shafts, sprockets, and drive belts that must be adequately guarded.

Ensure that the power take off (PTO) is fully guarded at all times and necessary warning signs are in place. Guards must cover the tractor stub shaft (master shield) and revolving power shaft (floating shield) as well as any revolving shaft on the application machinery. Roll-over protective structures (ROPS) and seat belts on tractors are vital in reducing hazards faced by the operator.

The Farm and Ranch Safety and Health Association ([www.farsha.bc.ca](http://www.farsha.bc.ca)) offers several publications on working safely with farm machinery.

## Fumigation equipment

Fumigant materials may be applied in solid, liquid, or gaseous form. For example, solid tablets or pellets containing aluminum phosphide may be spread in the area to be fumigated. Over time, these materials will react with moisture to produce phosphine gas.

Low-volatility liquid fumigants such as dichloropropenes may be applied with a pressure-fed applicator with a pump and metering device, or by a gravity flow unit. Highly volatile fumigants are handled in pressurized containers or tanks.

### Hazard points

Hazard points associated with pressurized containers or tanks include

a) **The container itself**

The container may become an explosive hazard if subjected to overheating, or it may leak if corroded. Some fumigants are flammable.

b) **Connection points**

In tubing that leads from container to application site, connections may leak if not adequately tightened.

### Note

If the fumigant transforms from a liquid to a gas as it proceeds through the application system, line freezing may develop due to heat absorption as the liquid vaporizes. Ensure the system is operated to prevent this hazardous condition.







# 6 General precautions when working with pesticides

**This chapter includes the following sections:**

- Introduction
- The pesticide safety program
- Personal protective equipment
- Transport of pesticides
- Pesticide storage
- Mixing and loading procedures
- Cross-connection control
- Application procedures
- Disposal of pesticides and containers
- Personal cleanliness and wash-up facilities







## Introduction

---

The types of procedures and protective measures needed to ensure a worker's safety when handling pesticides will depend on the hazards involved in the particular situation. Hazard is determined through consideration of the factors described in Chapter 5.

This chapter provides general information on pesticide safety programs, personal protective equipment, transportation, storage, mixing and loading procedures, cross-connection control, application, and disposal.

Chapter 7 provides additional information on control measures for specific types of pesticide applications, from field and orchard spraying to antisapstain treatment of lumber. Chapter 8 addresses the re-entry of workers to treated areas.







## The pesticide safety program

---

A properly planned pesticide safety program will cover at least the topics outlined in the following sections.

### Choice of pest control method

The choice of method will involve a number of factors including effectiveness of the method, worker health and safety, and environmental considerations.

From a chemical safety perspective, the best method is one that avoids the use of pesticides, for example through the use of alternative controls. If pesticides are used, they may be just one part of an integrated pest management program.

If a pesticide is used, one means of controlling the risk to workers is substitution, whereby a less hazardous product is chosen that reduces the risk to workers. Under the Occupational Health and Safety Regulation, if a substance is designated as a carcinogen, sensitizer, or reproductive toxin, then if practicable, the employer must replace it with another substance that reduces the risk to workers. If substitution is not practicable, then the employer must institute an exposure control plan as required by the Regulation, and ensure that the exposure of workers is kept as low as reasonably achievable below the exposure limit.

Designations of substances as carcinogens, sensitizers, and reproductive toxins are reported in the Table of Exposure Limits for Chemical and Biological Substances, which can be accessed at [WorkSafeBC.com](http://WorkSafeBC.com).

### Information and training

Where a worker may be exposed to a harmful substance, the employer must ensure that information on the substance, its harmful characteristics, and precautions for safety are communicated to the worker. The workforce must be trained in the safe handling, use, and storage of the substance, and where applicable in re-entry procedures following its application.

The pesticide label and material safety data sheet are two information sources that underlie the training program. An additional source is the set of specific work and emergency procedures developed at the worksite for use with pesticides.





---

## Qualified personnel

Workers who mix, load, or apply pesticides, or who clean and maintain pesticide equipment must be properly qualified. Under the Occupational Health and Safety Regulation, mixers, loaders, and applicators of moderately or very toxic pesticides must be over the age of 16 and hold valid applicators' certificates issued in accordance with the *Pesticide Control Act* and Regulation.

Workers who are in training for an applicator's certificate are exempt from the requirement for a certificate during the training period as long as they are under the direct supervision of a person who holds a certificate. Also, the obligation for a certificate does not apply to the application of biocides and slimicides in pulp and paper operations, or to the application of antisapstain materials. However, in such cases applicators must be properly informed about the hazards of the products involved and know how to use them safely.

## Hazard controls

If a pesticide has been selected for use, choices need to be made about the appropriate means of hazard control. Apart from substitution, there are three types of controls:

- **Engineering controls**

Examples include

- Enclosed cabs on tractors used for pulling spray equipment
- Ventilation systems in locations such as storage facilities
- Closed mixing and loading systems

- **Administrative controls**

These include work and personnel assignment procedures that reduce the risk. Examples include

- Moving workers who are not required for the pesticide application to a safe location
- Scheduling the application of pesticides in buildings for times workers are not present
- Posting warning signs after application
- Applying pesticides in fields when wind and other environmental conditions do not create a risk of pesticide drift

In some cases, very specific administrative controls may be needed for particular types of pesticides. For example, under the Occupational Health and Safety Regulation, if a pesticide is a sensitizer or a reproductive toxin, then the employer must develop procedures that may include protective reassignment of the worker.





---

- **Personal protective equipment**

Personal protective equipment includes protective clothing, gloves, headgear, eye protection, and respirators. This type of protection is only appropriate as the primary means of hazard control in cases where other means, such as substitution, engineering, and administrative controls, are not practicable or sufficient, or in temporary or emergency conditions.

Hazard controls must be in place for all aspects of pesticide use in the workplace, including

- Transportation
- Storage
- Mixing
- Loading
- Application
- Re-entry to treated areas

### **Inspections and investigations**

A complete pesticide safety program includes routine safety inspections of the workplace. Under the Regulation, inspections must be done at intervals that will prevent the development of unsafe working conditions. Where feasible, inspections will include the participation of the joint occupational health and safety committee or worker health and safety representative, as applicable.

In the event of accidents or other incidents, the employer needs to ensure that investigations are made as required under the *Workers Compensation Act* to identify causes of the incident and to ensure corrective measures are put in place to prevent recurrence.

### **Emergency procedures**

These must be established in the event of a poisoning, spill, or fire. All workers who may be affected must be properly trained in the procedures and the use of the equipment. First aid capability must be provided on site as required by the Regulation.





---

## Health surveillance

In some cases, it may be necessary to establish a health surveillance program in order to monitor and ensure worker well-being. Chapter 9 of this manual includes information on a cholinesterase monitoring program, which can provide a means of health surveillance for workers exposed to organophosphate and carbamate insecticides.

## Records

Under the Regulation, the employer must maintain a record of pesticide applications that includes

- The pesticide used and the location of application
- The date and time at which the application was completed
- The date on which workers were allowed to re-enter
- If applicable, the type of crop treated, the rate of application, and the number of acres or hectares treated

Records may also be required by environmental and other authorities.

The remainder of this chapter will deal with general control measures for the protection of workers, including

- Personal protective equipment
- Pesticide transport and storage
- Mixing and load procedures
- Application procedures
- Disposal of pesticides
- Personal cleanliness and wash-up facilities





## Personal protective equipment

---

Personal protective equipment should only be used as a means of hazard control if other means, such as substitution, engineering, and administrative controls are not sufficient to protect workers. Because of the nature of the hazards involved with pesticides and their means of application, personal protective equipment is often needed.

Under the Regulation, if a worker mixes, loads, or applies pesticides, or if a worker cleans, maintains, or handles equipment, materials, or surfaces contaminated with pesticide residues, the employer must ensure that

- The worker is provided with and wears suitable protective clothing and equipment
- Contaminated protective clothing and equipment is stored in a secure place and not used until it is laundered or otherwise cleaned
- If required, adequate facilities or services to launder contaminated protective clothing are available
- At least one change of outer protective clothing for each worker is available at the work site
- A change room or sheltered place is provided where workers can change clothes and store personal clothing while wearing protective clothing

The employer will also need to ensure appropriate personal protective equipment is provided to other workers who may be exposed to pesticides, such as workers who re-enter treated areas.

Depending on the circumstance, personal protective equipment will include any of the following:

- Clothing
- Gloves
- Headgear
- Eye protection
- Footwear
- Respirators
- Hearing protection

Each of these is discussed in turn below.





---

## Protective clothing

### *Selection*

The purchaser of any protective clothing should consider the following features:

- **Chemical resistance**

Different materials have varying abilities to resist penetration by pesticides. It is generally true that garments made of neoprene or natural rubber are more resistant than garments made from spun-bonded olefin, cotton, or polyester. Surface coatings of polyethylene and resins can increase the chemical resistance of less protective materials. Generally, the thicker the material, the more protection provided. Refer to Table 13 for specific information on chemical resistance of various fabric coatings.
- **Short-circuiting**

Inspect garments for any ways in which pesticides may penetrate weak points of protective gear. Safety features include jackets that can be secured up to the neck, pocketless exterior surfaces, and non-leak seams. Some seam designs in lightweight materials may permit leakage, especially under conditions where the fabric is stretched.
- **Washability**

Highly absorbent materials such as untreated cotton may be more difficult to clean than less absorbent materials.
- **Durability**

Refers to the ability to resist sudden tears, gradual physical abrasion, and the effects of sunlight. A material such as neoprene has good durability in all these respects, whereas polyethylene is relatively poor. See Table 13 for details.
- **Thermal properties**

The thermal comfort of fabrics depends on both colour and fabric type.





**Table 13: Properties of fabric coatings\***

<p><b>Butyl rubber:</b> A synthetic material with reasonable tear and abrasion resistance. Limited chemical resistance to emulsifiable concentrate solvents and some organochlorines. Can provide adequate protection against formaldehyde, triazine pesticides (e.g., simazine), creosote, and acidic pesticides such as glyphosate. There is evidence of effectiveness against organophosphates.</p>
<p><b>Fluoroelastomer:</b> Excellent resistance to tears and abrasion. Good protection against many chemicals, including some organochlorines, emulsifiable concentrate solvents such as xylene, and acidic pesticides such as glyphosate.</p>
<p><b>Natural rubber:</b> Resists tears and abrasion fairly well but can deteriorate in sunlight. Provides chemical protection against acidic pesticides such as glyphosate, but is not as effective with a number of other chemicals including some organochlorines, emulsifiable concentrate solvents, and wood preservatives.</p>
<p><b>Neoprene:</b> A synthetic rubber with good resistance to tears, abrasion, and effects of sunlight. Useful against acidic pesticides such as glyphosate, many of the wood preservatives and hydrocarbon solvents. Not very resistant to emulsifiable concentrate solvents such as xylene and some organochlorines.</p>
<p><b>Nitrile rubber:</b> A synthetic rubber that resists tears and abrasion well but deteriorates somewhat in sunlight. Provides substantial protection against formaldehyde, acidic pesticides such as glyphosate, some wood preservatives, some amine pesticides and organophosphates. Less resistant to some of the organochlorines.</p>
<p><b>Polyethylene:</b> Relatively poor tear and abrasion resistance, and can deteriorate in sunlight. Only somewhat chemical-resistant. Useful with acidic pesticides and aldehyde-type pesticides as formaldehyde. Less protective against many of the organochlorines and emulsifiable concentrate solvents.</p>
<p><b>Polyvinyl alcohol (PVA):</b> Relatively stiff material with low puncture and abrasion resistance. However, it has exceptional resistance to many organic solvents that pass easily through many rubbers. Can deteriorate in the presence of water.</p>
<p><b>Polyvinyl chloride (PVC):</b> Relatively good tear and abrasion resistance. Can become stiff at low temperature. Can provide substantial protection against amine-type pesticides (such as triazines), acidic pesticides such as glyphosate, some of the wood preservatives, and formaldehyde. Not as resistant to emulsifiable concentrate solvents such as xylene and some of the organochlorines.</p>
<p><b>Spun-bonded olefin (SBO):</b> A non-woven fabric that is used in disposable, lightweight clothing. Relatively poor tear and abrasion resistance. Can provide protection against pesticide dusts. Relatively poor protection against mist and sprays. Resistance can be improved somewhat with surface coatings such as polyethylene, synthetic rubber, and spray-on resins.</p>

\* These are recommendations only, *not* guarantees. No protective coating is completely chemical-resistant. The resistance of a particular item depends on factors such as the thickness of coating, method of production, and combination with other coatings. Check the pesticide MSDS for information on protective clothing. The sample MSDS in Chapter 2 of this manual shows clothing listed under Section 7 (Preventive Measures). You may also wish to check with the equipment supplier for recommendations on protective equipment for the specific pesticides used.





### Use

- Start each day in clean clothes and with clean protective garments that are free of holes or other defects.
- Coveralls are recommended even for transporting and storing pesticides. Wear shirt sleeves long.
- It is a good practice with disposable coveralls to select a size slightly larger than needed in order to reduce stretching at seams.
- With protective garments such as coveralls and rain suits, keep sleeves outside gloves and pants outside boots. If there is a chance that pesticide may drip from the glove onto the arm under the protective sleeve (for example, if it's necessary to work periodically with the arms raised upwards), tightly secure the sleeve of the protective garment to the glove. Commercially sold devices are available to provide a drip-tight seal.

Highest hazard activities include mixing and loading pesticides, application of pesticides when there is a likelihood of drift, and flagging in aerial applications. Ensure body protection matches the hazard. For example, flaggers are expected to wear full body protective spray suits.

When mixing and loading liquid pesticides, wear leakproof protective clothing such as an apron that extends below boot tops.

In spray applications where coveralls will be wet through to the skin by mist or spray, full spray suits may be necessary. Some suits are uncomfortable in hot weather. If possible, schedule such work activity for cooler periods.

### Care

- Check for small holes in protective clothing before use by holding it to light in an otherwise dark room. Repair or discard any torn or defective protective clothing.
- If clothing becomes wetted with pesticide, remove it immediately, and wash the affected area of the body. A number of poisoning incidents have resulted from contaminated clothing that was not removed until the end of the day.
- Do not store or wash contaminated clothing with personal or family laundry. Wash in hot water (at least 60°C). Bleach and detergent are particularly useful when washing clothes exposed to carbamates or organophosphates. Wash heavily contaminated fabrics twice.
- Store protective clothing in a clean location, and store synthetic materials away from sunlight.



**Protective gloves, apron and boots**

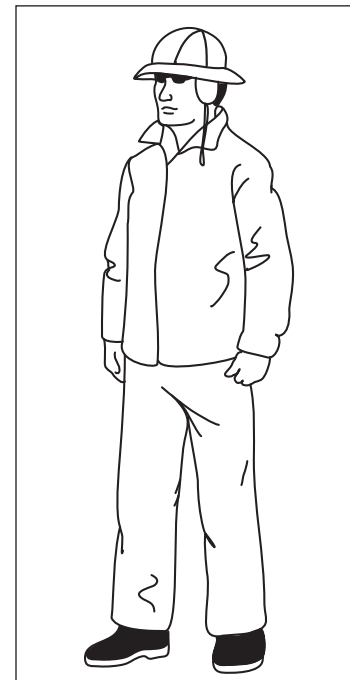

**Protective hat, spray suit and boots**





## Note

For information on disposable glove removal procedures, see the WorkSafeBC publication *Controlling Exposure: Protecting Workers from Infectious Disease* (BK129), available at [WorkSafeBC.com](http://WorkSafeBC.com).



## Gloves

### Selection and use

- Never handle pesticides without gloves, and never use leather or cloth gloves with liquid formulations. Canvas gloves, which permit pesticides to come in contact with the skin, can increase the chance of exposure.
- Chemical-resistant gloves are available in a wide variety of materials that include natural rubber, neoprene, nitrile, polyethylene, PVC, and PVA. Although materials such as neoprene have good acid and solvent resistance properties, no one single material is likely to provide protection against all types of pesticides. See Table 13 for details. Also, check the pesticide MSDS for recommendations on gloves. The sample MSDS in Chapter 2 of this manual shows gloves covered in Section 7 (Preventive Measures).
- Ensure that gloves are durable as well as chemical-resistant. For example, PVA is one of the best materials for protection against emulsifiable concentrate solvents such as xylene. However, PVA tends to dissolve in water and would quickly deteriorate when used with water-based formulations.
- Do not use cloth-lined gloves. Gauntlet gloves that extend up the forearm are superior to conventional hand gloves.
- It is important to prevent hand contamination when removing contaminated gloves. Three ways to minimize hand contamination during glove removal include:
  - Wash gloves prior to removal.
  - Wear a light pair of disposable plastic gloves under the outer gloves. Remove both outer gloves before removing the disposable gloves. Discard the disposables after each use.
  - Wear relatively loose-fitting outer gloves.

### Care

- Before use, check gloves for leaks. A simple test is to trap air in the glove by rolling the glove from the wrist toward the fingers and watching for air leaks when the pressurized glove is placed in a container of water. An alternative test is to fill the gloves with water and squeeze. Discard any gloves that leak, even from pinholes.
- Wash after use.
- Store out of sunlight in a clean location.



---

## Headgear

### *Selection and use*

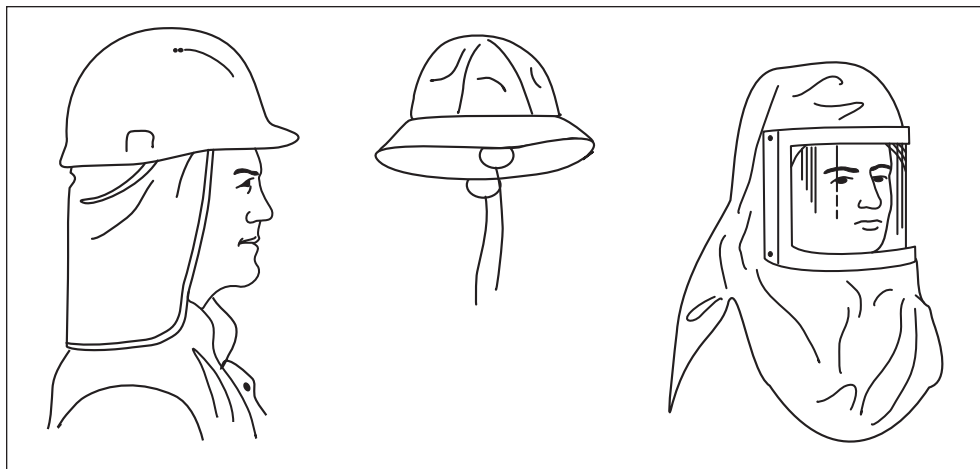

**Waterproof protective equipment including (left to right) hard hat with neck cape, rain hat, and hood**

- Workers spraying pesticides that could contact the upper body area must wear protective headgear made of waterproof, washable material.
- Helmets that cover the head, and hoods that cover the head, neck, and upper shoulders are particularly effective for preventing pesticide contact.
- If a hat is used, preferred designs include rain hats and wide-brim safety hats. If a standard safety helmet with a narrow brim is used, adding a rain trough (raised lip) around the bottom edge of the helmet can help prevent pesticide from dripping onto the neck. Bill caps do not provide adequate protection.
- Neck capes that attach to the back of some helmets are available to reduce spray drift contacting the neck.
- Sweatbands must be made of plastic or other non-absorbent material. Do *not* use bands of leather or cloth.

### **Care**

- Wash and dry headgear after use.
- Store in a clean location away from direct sunlight.





---

## Eye protection

### Selection and use

- **Chemical-resistant goggles** must be worn when there is a chance of chemical drift into the eyes (e.g., during spray applications). Good non-fogging designs are available. Do not use goggles that are meant only for protection against physical hazards from grinding and cutting.

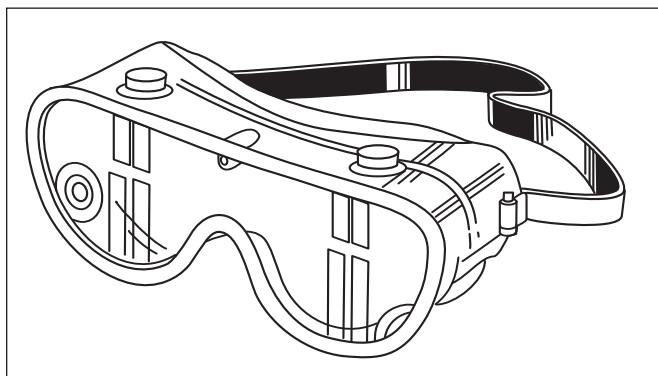

**Chemical-resistant goggles**

Hoods, helmets with visors, and full-facepiece respirators can also be used to provide eye protection in such situations.

- **Face shields** protect the eyes and face when there is a likelihood of splash from one direction and may be particularly useful during mixing and loading operations. Visors are sold in a range of sizes and shapes, and should be selected to provide the maximum coverage of the face and neck.

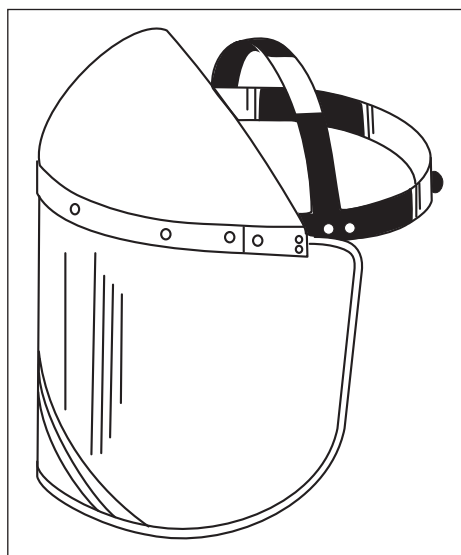

**Face shield**

Eye protection must meet the requirements of CSA Standard Z94.3-92, *Industrial Eye and Face Protectors* or another standard acceptable to WorkSafeBC.

Check the pesticide MSDS for recommendations on eye protection. The sample MSDS in Chapter 2 of this manual shows eyewear covered in Section 7 (Preventive Measures).

### Care

- Wash with soap and water at the end of each day's use.
- Store in a clean location away from sunlight.





---

## Footwear

### *Selection and use*

- Workers mixing, loading, or spraying pesticides should wear liquid-proof, acid- and solvent-resistant, unlined overshoes or boots. Protective footwear may also be needed in other circumstances such as when working in wood treatment operations or when re-entering treated areas.
- Leather or fabric footwear should not be used because these materials absorb pesticides. Knee-length boots are superior to ankle-length.
- Cleated or ribbed treads help to prevent slipping.

Check the pesticide MSDS for recommendations on footwear. The sample MSDS in Chapter 2 of this manual shows footwear covered in Section 7 (Preventive Measures).

A suspected pesticide fatality in the United States was attributed to an applicator's use of inadequate footwear. The applicator wore canvas shoes and developed raw wounds on his feet during several days of orchard spraying.

### *Care*

- Check condition before use. Discard or repair if leaks develop.
- Wash after each use.

## Respiratory protection

Appropriate respirators must be worn by workers who may be exposed to harmful levels of pesticides in the air.

WorkSafeBC has established exposure limits for many pesticides and formulators. These limits are listed in the Table of Exposure Limits for Chemical and Biological Substances, which can be accessed at [WorkSafeBC.com](http://WorkSafeBC.com).

If a worker is likely to be exposed to levels of chemical in air above exposure limits, steps must be taken in order to ensure worker safety. Engineering controls such as ventilation systems or enclosed cabs are the preferred way of reducing worker exposure to contaminants. However, in some pesticide applications, especially outdoors, such controls may not be feasible. In such cases, respirators must be used.

Proper respirators are those which are of a type approved by an agency acceptable to WorkSafeBC, and which are effective against the air





### Note

Some approvals are for protection against fumes, which are small metal particles that condense in the air from hot metal operations such as welding. The term *fume* must never be confused with the term *fumigant*. Fumigants are generally gases or vapours.

### Note

Dust masks (i.e., masks with one strap) are **not** respirators and are not acceptable to WorkSafeBC for use with pesticides.

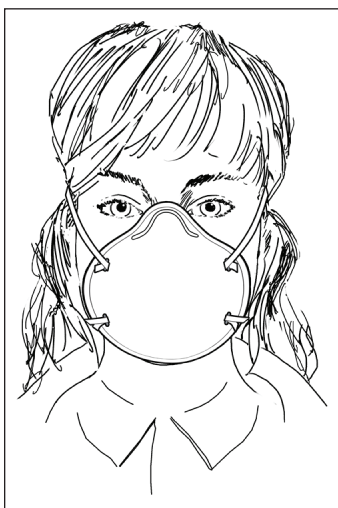

**Filtering facepiece respirator**

contaminants in question. The U.S. National Institute for Occupational Safety and Health (NIOSH) is an agency acceptable to WorkSafeBC.

The following list outlines some key points about respirators:

- Respirators are designed to protect against specific types of air contaminants. These include dusts, mists (coarse droplets), and vapours associated with pesticide use. In most cases, the contaminants are in the form of mists and vapours. However, dusts are an issue with solid pesticides and in situations where workers may dislodge dried residues from vegetation (e.g., in a treated field).

Respirators meeting NIOSH standards will show an approval code that begins with the letters “TC” (Testing and Certification) followed by an additional designation that indicates the type of protection provided.

- Broadly speaking, respirators are designed to either filter contaminated air or supply clean air.
- In order of increasing protection, three types of air-filtering respirators include filtering facepiece respirators, non-powered cartridge respirators, and powered air-purifying respirators.
- Two types of air-supply respirators include self-contained breathing apparatus (SCBA) and airline systems. These respirators provide high levels of protection. SCBAs are intended for short-term use such as firefighting and rescue, whereas airline systems can be used over longer periods.
- Respirator facepieces are typically either half-facepiece or full-facepiece. Full-facepiece designs provide a higher level of protection.

The rest of this section provides general information on respirator types, selection, use, and maintenance. For detailed information on respiratory protection, consult the WorkSafeBC manual *Breathe Safer*. The manual can be viewed online at [WorkSafeBC.com](http://WorkSafeBC.com).

### Types of respirators

#### *Filtering facepiece respirators*

These units, as shown in the graphic to the left, cover the nose and mouth. With this type of respirator, the facepiece itself is a filter.

Typically, these respirators are meant only for use against relatively low levels of air contaminants such as dusts and mist droplets. Some designs may provide protection against vapours.





### *Non-powered cartridge respirators*

These respirators have cartridge assemblies that screw onto a facepiece that covers the nose and mouth (half-facepiece), or that covers the nose, mouth, and eyes (full-facepiece).

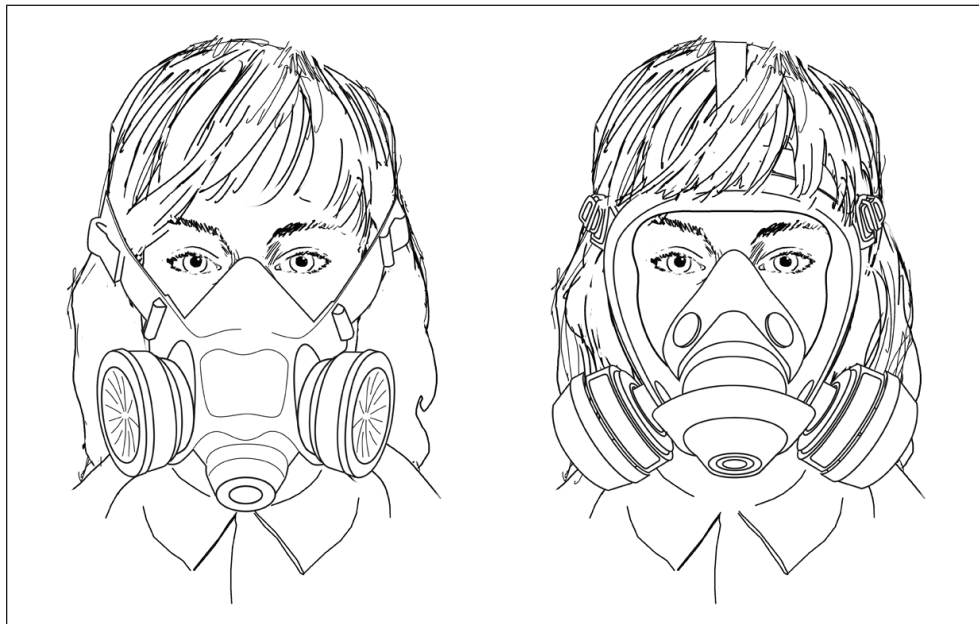

**Half-face respirator (left) and full-face respirator (right)**

Cartridges may be designed to protect against particulates. Some cartridges also provide protection against some pesticide vapours and gases. To be fully effective against pesticide spray, the filter must be effective against both particulates and vapours.

Cartridge respirators with half-facepieces often provide adequate protection against most pesticides at levels around or just above exposure limits. For levels well above these limits or where the pesticide causes eye irritation, a full-facepiece or a supplied-air respirator may be necessary.

#### **Note**

Some respirators are provided with canisters, which operate on the same principle as the smaller cartridges, but provide more filtration capability. Depending on the design, canisters may be attached to the facepiece or worn on the body.





**Powered air-purifying respirator**

### ***Powered air-purifying respirators (PAPRs)***

A PAPR is a design of cartridge respirator that uses an electrically powered pump to draw air through a filter at a certain minimum rate. The PAPR then delivers the air through a hose to either a tight-fitting facepiece or to a loose-fitting hood or helmet (sometimes called an *air hat*). With some models, the pump and filter unit can be attached either to the person or to equipment such as tractors.

Research shows that PAPRs with properly fitted facepieces provide better inhalation protection than those fitted with helmets or hoods. Some helmets and hoods may impair vision, and their use in uneven terrain may be hazardous. However, hoods and helmets provide some protection against skin exposure and may also reduce noise levels from application equipment.

#### **Note**

*Breathing assist* respirators are available on the market. These units look like PAPRs but don't meet the NIOSH airflow specifications of PAPRs. Ensure the unit is NIOSH-approved.



**Self-contained breathing apparatus**

### ***Self-contained breathing apparatus (SCBA)***

These units, unlike the preceding types, do not use filtered air. They come equipped with a cylinder of compressed air or oxygen carried on the back.

SCBAs have a limited use life generally of a half-hour or less.

They are the appropriate type of respirator in temporary, dangerous-to-life situations such as

- Short-term work in enclosed spaces such as greenhouses where dangerous levels of fumigants are present
- Emergency situations such as fires







### ***Airline respirators***

Like SCBAs, these units are provided with their own air supply.

Airline respirators draw air through a hose from a safe, distant supply and are suited for work in contaminated atmospheres where a long-term air supply is needed.

They must not be used in immediately dangerous to life or health (IDLH) situations unless the system includes a five-minute reserve air bottle attached to the user for emergency escape purposes.

### **Selection of respirators**

Respirators must be chosen in accordance with the Regulation. The following list outlines some basic dos and don'ts:

- If the pesticide has poor or otherwise inadequate warning properties, or if an oxygen-deficient atmosphere is likely to be present, don't use air-purifying respirators. Warning properties are discussed in Chapter 5 of this manual.
- If the pesticide releases any appreciable vapour or is a gas, do not use only a dust/mist filter. Since most pesticides give off vapours, at least a combination of chemical vapour and dust/mist filtration is necessary.
- If the pesticide causes eye irritation, a full-facepiece respirator should be used. Full-facepiece designs also help reduce skin exposure to pesticides.
- If levels of pesticide are substantially above exposure limits, a full-facepiece air-filtering or supplied-air respirator should be considered.
- If IDLH conditions exist or there is an oxygen deficiency, only SCBAs should be used (or airline [supplied-air] respirators if provided with a five-minute reserve air bottle). IDLH conditions include those where the concentration of the air contaminant is such that it could cause escape-impairing symptoms if the worker were exposed. IDLH levels are shown for some fumigant pesticides in Table 14. Oxygen deficiency exists when atmospheric oxygen levels are less than 19.5 percent.
- In firefighting situations, use only SCBAs.

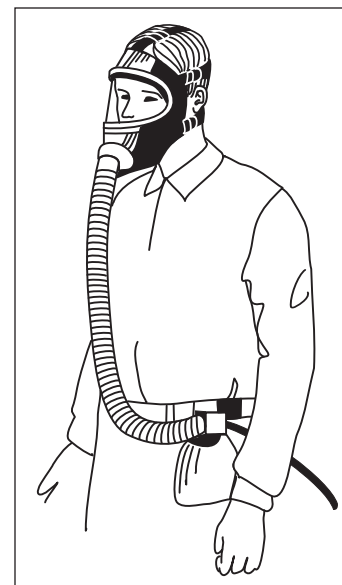

**Airline (supplied air) respirator**







**Table 14: IDLH levels for some fumigant pesticides\***

Pesticide	IDLH level
Chloropicrin	2 ppm
Formaldehyde	20 ppm
Hydrogen cyanide	50 ppm
Hydrogen sulphide	100 ppm
Methyl bromide	250 ppm
Phosphine	50 ppm
Sulfuryl fluoride	200 ppm

\* Levels refer to parts of air contaminant per million parts of air. Source: *NIOSH/OSHA Pocket Guide to Chemical Hazards* (2005). All IDLH values represent judgments and should be considered the maximum concentration from which one can escape without escape-impairing symptoms and irreversible health effects.

### Use and maintenance of respirators

1. **Before use, ensure the respirator is in good working order.** For example, check the half-facepiece chemical cartridge respirator as follows:
  - **Particulate filter**  
Check for NIOSH approval, proper connection to the respirator, and condition of filter.
  - **Combination gas and particulate cartridge**  
Check for NIOSH approval, proper connection to the respirator, and condition.
  - **Gaskets**  
Ensure these are in place and in good condition.
  - **Inhalation valves**  
Ensure these valve flaps are clean and lie flat against the inhalation port.
  - **Exhalation valve**  
Ensure valve guard is in place, that valve functions correctly, and that valve and seal are clean.
  - **Facepiece**  
Ensure that facepiece is clean and is not warped or cracked, especially along the sealing surface that contacts the skin.



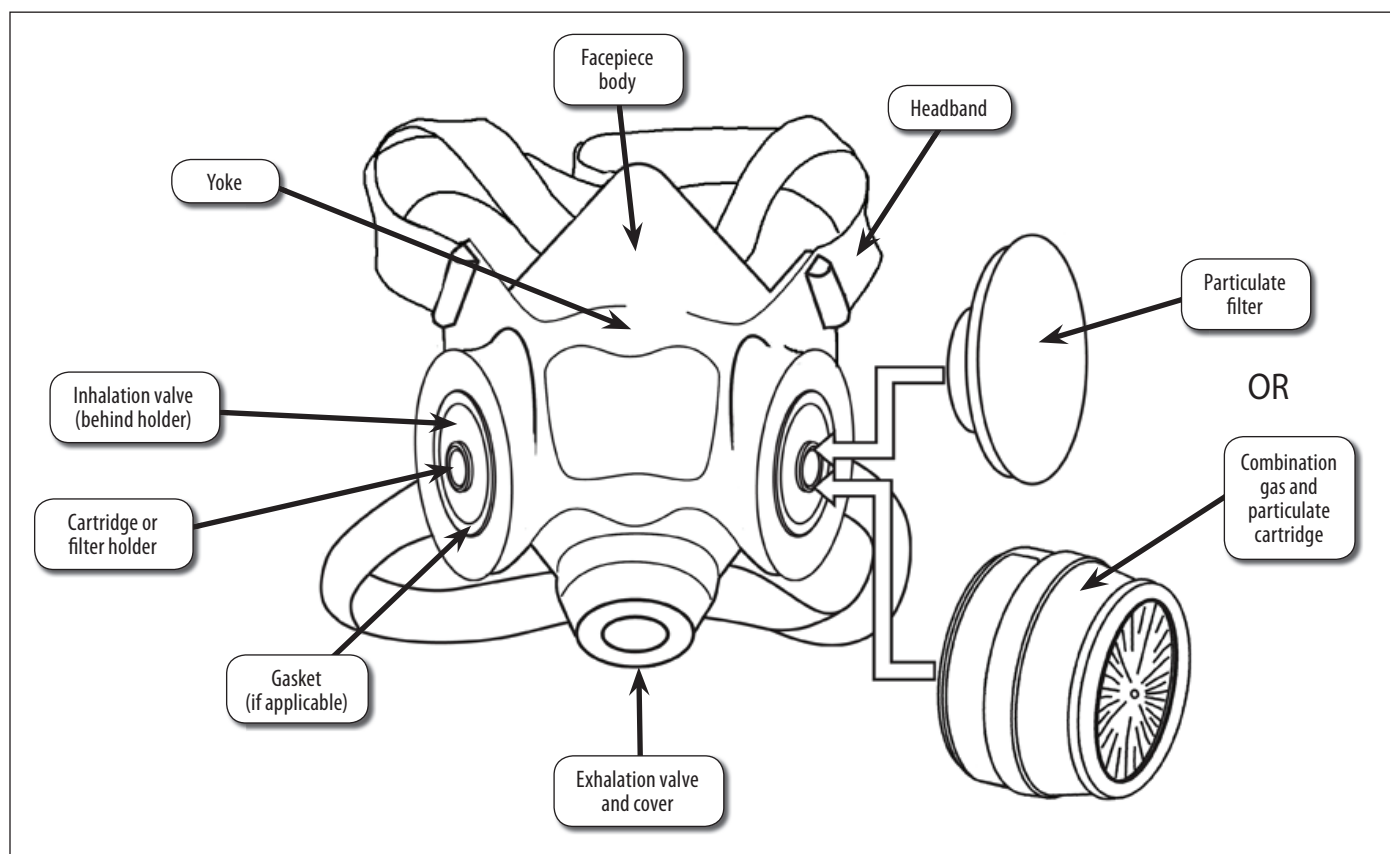

**Figure 11: Diagram of a cartridge respirator**

2. **After putting on the respirator, ensure there is an adequate seal between the facepiece and skin.** Quick field checks of the seal are the negative pressure (inhalation) check and positive pressure (exhalation) check. The Regulation requires that you do one of the following checks before each use of a respirator:

– **Inhalation check**

Place the palm of the hands over the cartridge assemblies or inhalation area and breathe in. If no air enters and the facepiece collapses slightly, the respirator is properly fitted.

– **Exhalation check**

Place the palm of the hand or a thumb over the exhalation valve guard and press lightly. Breathe out to cause a slight pressure inside the facepiece. If no air escapes, the facepiece is fitted properly, and the inhalation valves are seating correctly. If air escapes, adjust the respirator and check again, or check the condition of the exhalation valve.





A more rigorous test of facepiece seal is provided by the *qualitative fit test*, in which respirator wearers are exposed to a material such as an irritant smoke or an odorous vapour such as banana oil. The wearers carry out a series of exercises such as normal breathing, deep breathing, nodding the head up and down, turning from side to side, and talking. If the respirator wearers can detect the smoke or odour inside the facepiece, they should readjust the seal to get a proper fit, or select another facepiece that provides a seal.



**Inhalation check (left) and exhalation check (right) for a half-facepiece respirator**

The Regulation requires that such fit tests be carried out

- Before initial use of a respirator
- At least annually after that
- Whenever there is a change in the respirator facepiece used
- Whenever there is a change to the user's physical condition that could affect the respirator fit

For more detailed information on fit tests, see the WorkSafeBC publication *Breathe Safer*, which can be accessed at [WorkSafeBC.com](http://WorkSafeBC.com).





3. **To ensure a good fit with respirators, do not permit any object or item to interfere with the facepiece seal.** Cloth facelets around the facepiece, beards (in the area of the respirator seal), and glasses (for full-facepiece respirators) all interfere with the seal. Some respirator manufacturers provide a modification of full-facepiece masks that can accommodate glass lenses.
4. **Change filters when breathing becomes difficult, and when any pesticide odour breakthrough is noticed.** It is impossible to predict when breakthrough will occur with cartridges or canisters. The use life depends on the level of exposure, type of formulation, humidity, and worker rate of breathing. In addition, cartridges do not absorb some types of vapour nearly as effectively as others.

As a rough estimate, in moderate exposure conditions, it is reasonable to expect about four to eight hours of useful life for filters.

5. **Ensure proper use of respirators in cold and hot weather.** Low temperatures may fog lenses on full-facepiece respirators. Anti-fogging compounds may help prevent fogging down to 0°C. For lower temperatures, nose cups are available with some respirators. Nose cups help direct the moist, exhaled air so that it doesn't contact the lens.

In hot weather, the stress of wearing respirators can be reduced by using lightweight models and those that provide a powered flow of air.

6. **Inspect and clean respirators after each use.** Details of a recommended cleaning and maintenance procedure are provided in the WorkSafeBC publication *Breathe Safer*.
7. **Store respirators in a clean location and away from sunlight, solvents, extreme cold or heat, and excessive moisture.**
8. **Maintain and inspect respirators routinely according to the manufacturer's instructions.** Cartridges and canisters have limited life spans. They should be marked with the date they are first used or put into service, and replaced according to a schedule provided by the manufacturer. In addition, replace the cartridge right away if you experience any breakthrough of the contaminant into the facepiece.

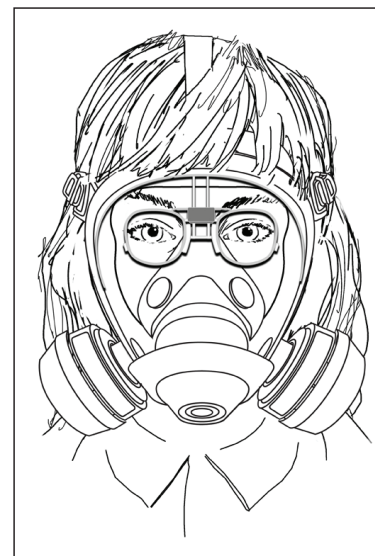

**Full-facepiece respirator with corrective lens attachment**

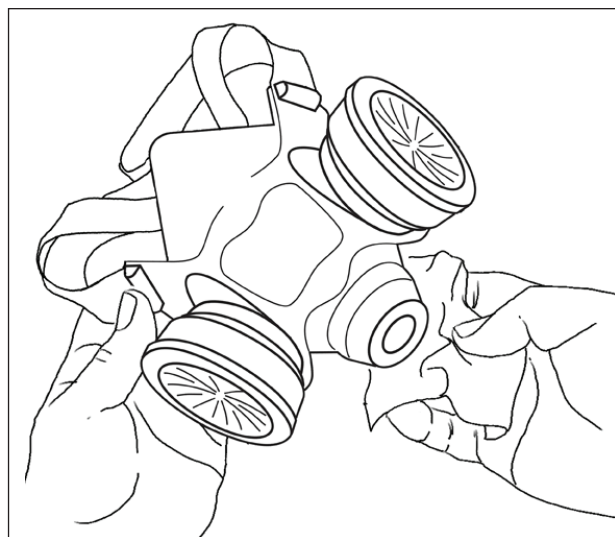

**Use a moist wipe to clean the facepiece when a quick touch-up is needed.**





---

## Hearing protection

Workers who operate application equipment such as tractor-drawn boom sprayers, air-blast sprayers, and foggers may be exposed to noise levels that can cause hearing loss.

There are maximum safe limits for noise exposure in the workplace. **If you have to raise your voice to be heard to a person an arm's length away, the noise is probably excessive.** If your ears ring or sound seems muffled when you shut down equipment, you can be sure your hearing has been harmed at least temporarily.

### Selection of hearing protection

Two basic kinds of protective devices are earmuffs and earplugs. Earmuffs consist of two padded cups that cover the ears and are held together by an adjustable headband. Earplugs are devices that fit into the ear canal.

Plugs may be preferred if safety headgear interferes with earmuffs. Earmuffs may provide warmth on cold days. Note that some earmuffs have fluid-filled cuffs, and you should check the fluid freezing point for work in cold conditions.

WorkSafeBC requires that hearing protection be selected according to *CSA Standard Z94.2-02, Hearing Protection Devices – Performance, Selection, Care, and Use*. Check with your supplier to ensure the hearing protection you are considering will provide adequate protection against the noise from your equipment.





---

## Use

### *Earmuffs*

Ensure that other personal protective equipment (e.g., hard hat, eyewear, and respirator) and hair do not interfere with the seal between the cuff and the side of the head.

Ensure the tension of the headband is adjusted to hold the muffs snugly against the head.

### *Earplugs*

When fitting the flange type of reusable plugs, the flanged part goes into the ear canal, with the tab end outside the ear.

With foam- or sponge-type disposable plugs, roll the plug between the thumb and forefinger before inserting. Then lift the ear up and back, and insert the plug well into the ear canal using a twisting motion. Hold the plug in until the material expands.

If you feel pain when inserting plugs, see your doctor. You may have an ear infection or wax buildup in the ear.

For further information on hearing protection, consult the WorkSafeBC publication *Hear for Good*, which is available at [WorkSafeBC.com](http://WorkSafeBC.com).





## Transport of pesticides

---

Legislation on the transport of pesticides and other dangerous goods on public roadways includes the *Transportation of Dangerous Goods Act* (Transport Canada) and related provincial environmental legislation. In addition, the Occupational Health and Safety Regulation has requirements that apply to vehicles used by workers.

Some safe pesticide transportation practices include

- Attach warning placards to the vehicle that identify the hazardous contents being transported, as required by relevant federal and provincial legislation.
- Carry a spill cleanup kit that includes items such as a shovel and chemical neutralizer. Ensure that the driver is trained in emergency spill procedures.
- Inspect containers for defects prior to transport. Do not accept materials in rusted, dented, or otherwise defective containers.
- Never transport pesticides along with food, feed, or consumer goods.
- Do not transport pesticides in the passenger compartment of any vehicle. Do not allow anyone to ride in the back of a truck along with pesticides.
- Secure all pesticide containers to prevent accidental spillage. Be particularly careful with paper and glass containers. A safe practice is to transport glass containers in form-fitting, foam-lined shipping packages often used by chemical companies.
- Protect wettable powders and dusts in paper containers from rain and moisture.
- Avoid transporting pesticides on wooden truck beds. If your truck is provided with a wooden bed, use a storage box made of non-absorbent material or heavy plastic sheeting spread on the truck bed. Pesticides spilled on wooden truck beds are almost impossible to remove. This may cause contamination of any materials carried afterwards in the truck.

Note: Check the pesticide MSDS for information that may assist. For example, the sample MSDS in Chapter 2 of this manual covers handling procedures and shipping information in Section 7 (Preventive Measures).







## Pesticide storage

---

The Occupational Health and Safety Regulation provides requirements for the safe storage of chemicals in general, and pesticides specifically.

Some provisions that are specific to pesticides include

- Pesticides must not be stored in areas where food preparation occurs, in lunchrooms, or in food storage facilities.
- For the storage of bulk or reserve quantities of pesticides, the employer must supply a storage facility that meets the design criteria stated in this manual.
- Factors to be considered in the facility design include maintenance of minimal quantities, compatibility of pesticides, strength of shelving materials, and containment of spills.

Safe pesticide storage involves both storage facility design and safe practices in the storage facility. Special consideration must also be given to mobile storage facilities.

### Facility design

Factors to consider when designing a storage facility include location, building materials, entrances, ventilation, plumbing, lighting, and insulation. Figure 12 shows the recommended layout of a pesticide storage shed.

#### Location

- Always store pesticides in a facility separated from work areas and habitation.
- Depending on the quantity of pesticides, the facility may be a cabinet, room or shed. For larger quantities of pesticides, a shed, completely removed from buildings such as barns, houses, and warehouses, is preferred. In case of fire, the loss of a small shed is far less costly than a larger structure such as a barn or warehouse.
- Do not store pesticides in a basement. Dangerous vapours and gases are more difficult to ventilate from a basement than from a ground-level structure.
- Select a storage site as far as possible from human and animal habitation and on the downwind side.





- 
- If possible, choose a shady site.
  - Select a site where surface runoff water used to fight a pesticide fire will not contaminate a surface water body or well.
  - Ensure the storage area is above the highest recorded flood level.

#### **Building materials**

- Whenever possible, use fire-resistant materials. Gypsum board interiors are preferable to wood panelling. Paints or other sealants should be used on absorbent surfaces.
- A concrete floor with curbs to contain spills is preferred to wood. Paints or other sealants should be used on absorbent floor surfaces.
- Explosion-proof wiring, switches, and fixtures are necessary for storage of flammable pesticides.

#### **Entrances**

- Provide locks on entrances.
- Securely attach warning signs outside or next to all entrances. Signs should effectively communicate DANGER to anyone who cannot read or understand English.

#### **Ventilation**

- If the storage facility is not used as a mixing area, a reasonable level of ventilation is six air changes per hour. For a facility 3 metres (about 10 feet) high, this would mean about 30 litres per minute (1 cubic foot per minute) of ventilation for every one tenth of a square metre (1 square foot) of floor area. If mixing is done indoors, additional ventilation will likely be required.
- For small quantities of pesticide, natural ventilation may be sufficient. Structures with no vapour barriers or weather-stripping may have natural air leakage of one to three air changes per hour.
- The best location for the ventilation control switch is outside the storage area. One technique is to interlock the ventilation control with the light switch.



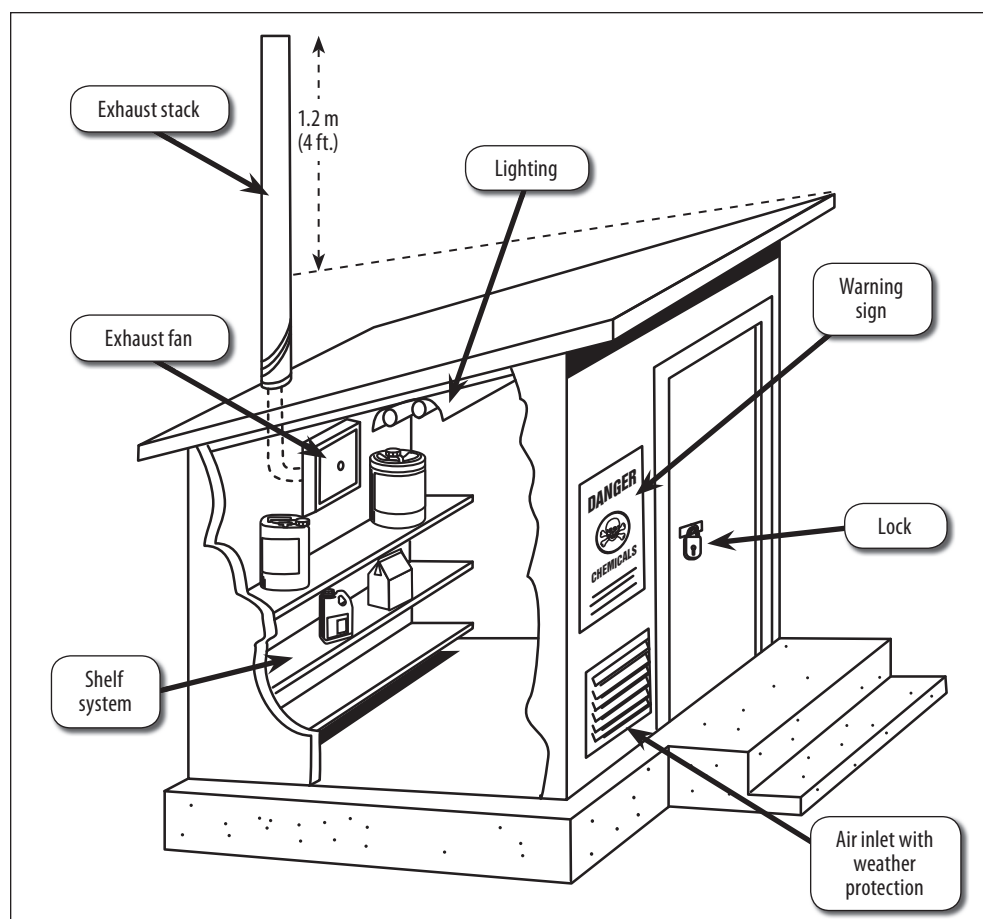

**Figure 12: Recommended pesticide storage facility**

- For effective ventilation, ensure that exhaust fans are located so as to pull airborne pesticides away from the work areas, and provide an inlet air vent for make-up air. One technique is to mount exhaust fans near the pesticide shelving and mixing areas and to provide inlet grates in locations such as a far wall or in the door.

### **Plumbing**

Safety plumbing features include

- A floor drain that leads to a sump or other appropriate spill and washings collection facility.
- Backflow prevention devices in the piping systems that supply water for mixing pesticides.
- Appropriate washing and shower facilities for routine cleanup and emergency situations. Emergency wash facilities should be located close to mixing areas.





### Lighting

- Lighting must be sufficient to ensure safety and to permit easy reading of labels on pesticide containers.
- 100 lux (10 foot-candles) is required in actively used storage areas and 200 lux (20 foot-candles) in areas where pesticides are mixed.

### Insulation from heat and cold

- Locate pesticide shelving away from steam pipes, windows with southern exposures, or similar heat sources.
- Provide insulation to maintain storage temperatures in the range of 5°C to 30°C. A number of pesticides such as those shown in Table 15 decompose, and in some cases explode, at temperatures not far above ordinary room temperatures. Freezing temperatures can inactivate some pesticides.

**Table 15: High temperature hazards of some pesticides**

Pesticide	Warning
Acephate	Decomposes rapidly above 40°C.
Azinphos-methyl	Container may explode after heating above 85°C.
Malathion	Decomposes above 50°C.
Maneb	Can decompose and undergo spontaneous combustion at elevated temperatures.

### Safe storage practices

- **Store the minimum quantities of pesticides needed.** The smaller the amounts, the less the fire hazard, ventilation needs, and loss of pesticide due to evaporation, leakage, or deactivation.
- **Wherever possible, store pesticides on shelves.** Containers on the floor are often a tripping hazard and are more likely to suffer corrosion or other damage. Metal shelving or well-painted wood shelving is preferred. The bottom shelf should be set at least 10 centimetres (4 inches) above floor level to allow a “kick space” under the shelf. Top shelves must be within easy reach. It is not safe to handle chemicals above face levels.
- **Whenever possible, separate different types of containers.** One recommended practice is the three-shelf system, with small paper containers on the top shelf, small metal and plastic containers on the





---

middle shelf, and large metal and plastic containers on the bottom. If any glass containers are used, they are least likely to break in the event of a fall if placed on the bottom shelf. Bottom shelves should also be used for large containers such as drums where space permits. An alternative practice is to place drums on pallets next to the wall.

- **Always separate incompatible pesticides and chemicals.** In some pesticide publications, the term “incompatible” is used to describe two (or more) pesticides that reduce each other’s effectiveness if applied at the same time. However, from a health and safety perspective, the term “incompatible” describes those chemicals which, on contact with each other, can create a hazardous condition such as a fire, explosion, or release of toxic gases. Such chemicals must be separated from each other in storage areas to minimize the chance of mixing in case of spills.

Examples of incompatible chemicals include

– **Combustible pesticides and oxidizers**

Most pesticides are easily ignited or oxidized. This is especially true of organophosphate insecticides.

Keep such pesticides away from oxidizers such as

- The pesticides cyhexatin, dodine, and sodium chlorate (Ureabor)
- Fertilizers that contain ammonium nitrate
- Cleaning agents such as bleach

**WARNING**

**Ureabor is a very strong oxidizer  
and should not be stored on wooden shelves.**

– **Some pesticides and water**

Pesticides such as dazomet and aluminum phosphide will release toxic gases on contact with water. Maneb and mancozeb are combustible on contact with water. Ensure such pesticides are stored away from all sources of water.

– **Pesticides and corrosives**

Many pesticides are incompatible with corrosives such as strong acids or caustics. Keep corrosives separated from such pesticides.

– **Some pesticides and metal**

Pesticides such as difenzoquat, methyl bromide, and paraquat will produce flammable hydrogen gas on contact with galvanized metal. Make sure to prevent contact between such pesticides and metals.







- 
- **Never store personal protective equipment, food, or food utensils with pesticides.**
  - **Always store pesticides in the properly labelled container with the label clearly visible.** A good practice with paper containers is to place the containers in transparent plastic bags or other similar containers for extra security.
  - **Inspect pesticide containers and contents regularly.** As a general rule, pesticides have a shelf life of about two years. Some pesticides such as naled and paraquat corrode metal containers. Some pesticides can become explosive when dry.
  - **To prevent problems, record when pesticides are purchased, make periodic checks of containers and contents, and rotate stock.** The Pesticide Storage Inventory form (page 116) will help with the management of stored chemicals.
  - **Eliminate all defective containers.** If the original pesticide container breaks, repackage the pesticide as follows:
    - Put it in a container that is similar to the original; for example, replace plastic with plastic. (An alternative with torn paper containers is to patch the tear and place it in a clear plastic bag secured on top. Do not cover up the label.)
    - Label any new container with a replacement supplier's label or a workplace label which shows the trade name, common name, concentration of the chemical, PCP number, safe handling information, and reference to the MSDS (where available).
  - **Be prepared for emergencies.** It is a safe practice to provide emergency supplies such as a first aid kit and spill cleanup equipment at the pesticide storage area. Emergency phone numbers should be displayed next to the telephone. See Chapter 9 for details on emergency procedures.





### Note

When considering storage practices, check the pesticide MSDS for information on issues such as flammability, chemical stability, and incompatibility, along with recommendations on storage practices. The sample MSDS in Chapter 2 of this manual covers these matters in Sections 4, 5, and 7 of the data sheet. Also, ensure that storage practices meet requirements of environmental authorities.

## Mobile storage facilities

In the structural pest control and silviculture industries, pesticides are frequently transported for extended periods of time in one vehicle. As a result, the vehicle becomes a mobile storage facility, and appropriate precautions need to be taken.

Hazard concerns include

- Prevention of driver's inhalation of harmful levels of pesticide
- Adequate containment of pesticides in case of vehicle accident
- Prevention of pesticide contamination of personal protective clothing and respirators
- Provision for storage of contaminated protective clothing away from driver or passenger areas
- Provision of adequate quantities of wash water if the application site is far away from a running water source

From a safety viewpoint, a pick-up truck with a canopy offers the most advantages. Cars and station wagons are not recommended. The containment of pesticides in a locked truck canopy eliminates worker exposure to pesticides during driving and can help ensure worker safety in case of a vehicle accident.

One particularly useful type of canopy is the *space cab* (utility canopy), which provides a series of lockable compartments along each side of the canopy. The space cab also provides an interior space, accessed from the rear, for storage of equipment and bulk pesticides.

Compartments can be used to provide separate storage for personal protective gear, wash water, first aid, and incompatible chemicals.





## Mixing and loading procedures

---

### Qualifications and training

As outlined at the beginning of this chapter, mixers and loaders must be properly qualified and trained.

### Pesticide information

Before handling a pesticide, read the product label and consult the material safety data sheet.

### Personal protective equipment

Before handling a pesticide, put on the proper personal protective equipment. In many mixing and loading procedures, necessary protective equipment includes

- Chemical-resistant footwear
- Chemical-resistant apron
- Coveralls
- Chemical-resistant gloves
- Face shield
- Respirator

### Emergency facilities

Ensure that proper emergency facilities, including washing facilities and first aid equipment, are provided. Emergency phone numbers must be made available at the mixing and loading site.

### Closed systems

Closed mixing and loading systems have been shown to reduce worker exposure to pesticides, and must be used when required.

### Environmental conditions

Mix pesticides only in good light and with adequate ventilation. Stand upwind to minimize airborne exposure.







## Cross-connection control

---

Water is the major carrier in liquid pesticide applications. Whenever an applicator adds water to pesticides, a cross-connection may result, with the risk of contaminating the source from which the water is drawn.

### Some terms to know

- **Cross-connection**  
Any link through which a contaminant may enter a water supply as a result of backflow.
- **Backflow**  
Reverse movement of water in a system from the use point back to the source. Backflow may be due to either back-siphonage or back-pressure (or both).
- **Back-siphonage**  
Reverse flow in a water system due to negative pressure in the supply piping. Can be caused by loss of water pressure due to firefighting, breaks in the water line and so on. The effect is similar to sipping a drink through a straw.
- **Back-pressure**  
Reverse flow due to an increase in the pressure at the use end of a system above the pressure at the supply end. Back-pressure occurs when systems such as mix tanks and irrigation lines are well above the height of the supply source.

Reverse flow situations are usually due to drops in supply line pressure and involve back-siphonage. However, back-pressure is often a second factor in such situations.

If there is a drop in supply line pressure, the reverse flow will be experienced in different ways at different points, as shown in Figure 13. At the highest points in the diagrams (points A), backflow is experienced only as a vacuum (that is, back-siphonage). At points B, however, the backflow occurs partly due to back-pressure because of the pressure of the column of water above point B.

It is always advisable to place those backflow prevention devices that protect against siphonage effects only at the highest point in the water system.





**1. Spray mix tank filled from a pressurized water source such as house or building hose taps, and where the discharge end of the filling hose is below the overflow point of the tank. If the supply line pressure drops low enough, reverse flow from the tank can occur.**

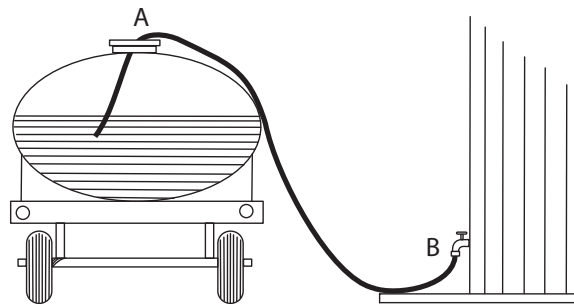

**2. Spray tank filled from surface water body such as a pond, ditch, or stream through the filling hose as shown. With some pump designs, reverse flow can occur when the pump is turned off.**

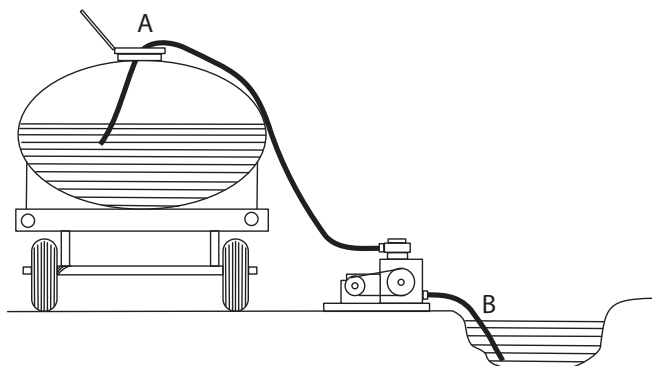

**3. Aspirator unit used to spray pesticides; e.g., a small hand-held aspirator powered by a garden hose. Reverse flow of contaminated material will occur with sufficient drop in line pressure.**



**4. Chemical injection into a pressurized irrigation system. Chemicals may be either fertilizers (fertigation) or pesticides. Chemical will flow into supply line with sufficient drop in supply pressure.**

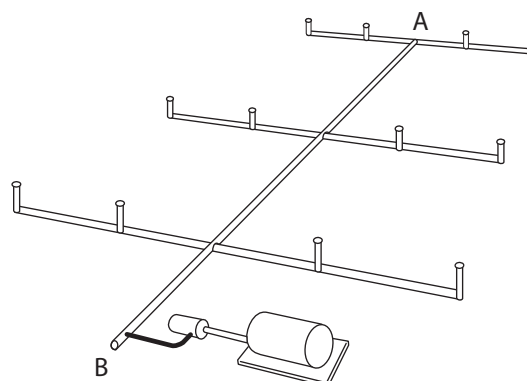

**Figure 13: Examples of cross-connections**





---

## **Hazards of cross-connections**

Documented cases of illness and death have been attributed to cross-connections. Those at risk when drinking water becomes contaminated may include co-workers, family members, and the public.

### **Two cases of cross-connection mishaps**

- A pesticide applicator used an aspirator attached to a garden hose to spray a weed killer. While at the job, there was a flow reversal in the water supply. The man disconnected the hose and, feeling thirsty, drank from the tap that had supplied the hose. Pesticide in the water killed him.
- A pesticide applicator, while treating a church for termites, left a garden hose submerged in a bucket of chlordane during mixing. The church was located on a steep hill, and its water system experienced negative pressure during the mixing process. The chlordane that was sucked into the drinking water system resulted in 15 people becoming ill and required the replacement of the plumbing in the church.

## **Backflow prevention devices**

There are five basic types of devices available to prevent backflow at a cross-connection. The choice of device depends on three factors:

- Source of reverse flow pressure (back-siphonage alone or back-pressure as well)
- Length of use of the supply system
- Level of hazard

The five preventive devices are listed in Table 16. Diagrams are shown in Figure 14. Of the five, the air gap is one of the simplest to install. Air gaps are, however, only one line of defence, and may not be feasible in some systems such as chemical injection irrigation. To be safe, air gaps must be of a design that cannot be tampered with by persons unfamiliar with the need for the gap.

The four types of in-line check valve assemblies are designed for the specific situations described in the table. Ensure the assembly selected is an approved design and is installed correctly. For example, reduced pressure devices cannot be installed below ground. All in-line systems require regular maintenance. Pressure vacuum breakers, double check valves, and reduced pressure devices should be tested upon installation and thereafter annually by trained personnel.





**Table 16: Types of backflow prevention devices**

Device	Description	Use	Warning
<b>1. Air gap</b>	Vertical physical separation between the discharge end of a water source and the overflow level of a receiving container of a contaminated liquid.	For filling spray mix tanks from water sources such as hose bibbs and surface water bodies such as ponds.	<p>As a rule of thumb, maintain a separation at least two times the diameter of the discharge pipe between the end of the pipe and the overflow level of the receiving container.</p> <p>Increase the separation where necessary (e.g., in case of foaming).</p> <p>Best used with rigid piping systems. It is far more difficult to ensure an air gap with flexible hose.</p>
<b>2. In-line reverse check valve assemblies</b>			
<b>Atmosphere vacuum breaker</b>	Single check valve with atmospheric vacuum breaker unit.	Protective devices on hose bibbs and generally on the discharge side of the last control valve.	<p>Must never be subjected to back-pressure, which can cause the check valve to modulate. Install at the highest point in the system wherever possible.</p> <p>Do not use with continuous pressure, which may cause the valve to seize in the open position.</p>
<b>Pressure-type vacuum assembly</b>	Spring-loaded float and disk with independent first check valve.	For use in continuous pressure water systems. Install at the highest point in the system whenever possible.	Effective against back-siphonage only. Does not assure protection against back-pressure. Should be installed at least 30 cm (12 in.) above the highest outlet on the non-potable water system.
<b>Double check valve assembly</b>	Two independent check valves in series.	Used in continuous pressure situations that may be subject to back-pressure.	Do NOT use in high hazard situations.
<b>Reduced pressure principle backflow preventer</b>	Two independent check valves with intermediate relief valve.	Use with all cross-connections subject to back-pressure or back-siphonage and where there is a high hazard from contamination. Good for continuous pressure systems.	Although of superior design, this device, like all in-line backflow preventers, must be adequately maintained.





**1. Air gap**

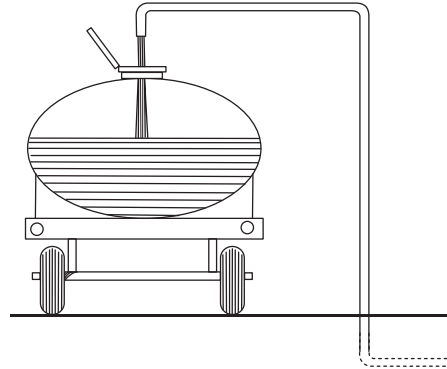

**2. Atmospheric vacuum breaker**

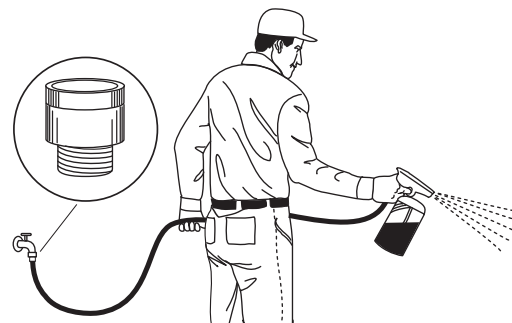

**3. Reduced pressure backflow preventer (with a vehicle)**

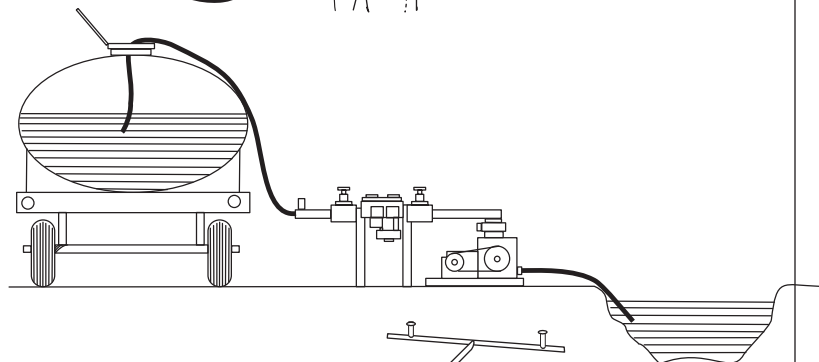

**4. Reduced pressure backflow preventer (in an irrigation system)**

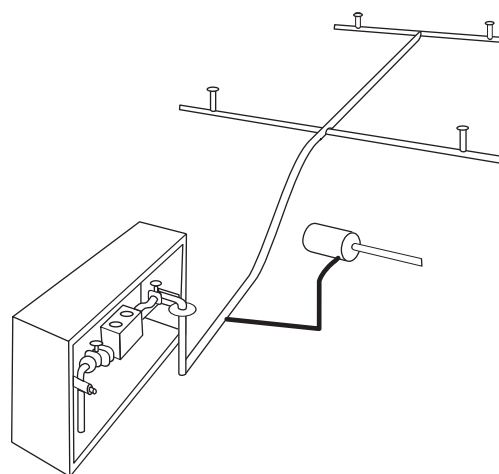

**Figure 14: Backflow prevention systems**





## **Application procedures**

---

### **Qualifications and training**

Pesticide applicators must be qualified and trained according to legislated requirements as outlined at the beginning of this chapter.

### **Pesticide information**

Before applying pesticides, read the product label and consult the material safety data sheet.

### **Calibration and maintenance**

Ensure that the application equipment is calibrated and in safe running condition before use. Refer to Chapter 10 for maintenance and calibration directions.

### **Personal protective equipment**

Ensure protective equipment matches the hazard. See Chapter 7 for details on such equipment in various application situations.

### **Emergency procedures**

Make sure that emergency facilities such as wash water are at hand in the event of an accident. When a worker is applying a pesticide, particularly one that is very toxic, it is necessary to periodically check the well-being of the worker. When a worker is applying pesticides in a greenhouse, mushroom barn, or similar enclosed space, the work must be done in a manner that rescue can be carried out by a person equipped and able to do so.

### **Environmental procedures**

As a general rule, do not apply pesticides if wind speed is more than 8 km/h (5 mph) or if air temperature is above 30°C.





---

## Protection of other workers

Before application begins, post required warning signs at normal points of worker entry to the spray site. Signs must warn of the danger and specify the required restricted entry interval. Refer to Chapter 8 for details. Ensure that other workers are moved to a safe area. If practicable, schedule pesticide application in buildings for times when the buildings are unoccupied.

Take all reasonable precautions to prevent drift or spread of the pesticide. If pesticide has drifted to another worksite, the Regulation requires that the employer in control of the pesticide must notify the employer of the second worksite so that safety measures can be implemented.

## Equipment operation

Use pressures, nozzle types, spray angles, etc., that are recommended or required by the responsible authorities. Do not handle equipment in an unsafe manner. See Chapter 7 for details of equipment operation in various application situations.

## Highway safety

Workers involved in spray work along or near road rights-of-way must be protected against traffic hazards. See Chapter 7 for details of a traffic safety program.

## Electrical safety

Sources of electrical power may present a hazard when water-based formulations are sprayed nearby. This could occur, for example, when trees are sprayed near roadside power lines or when air-blast operations are carried out near stingers. See Chapter 7 for details on safe procedures for spraying near electrical equipment.

## Records

A well-managed pesticide safety program includes a record of applications. The Regulation's requirements are outlined on page 91. Also, ensure that records meet the requirements of environmental authorities.

### Note

The B.C. Ministry of Agriculture and Lands has partnered with industry associations to offer a series of crop production guides. The guides cover currently recommended practices for the production of specific crops. Some guides include forms for recording details of pesticide applications. For more information, visit [www.agf.gov.bc.ca/cropprot/prodguide.htm](http://www.agf.gov.bc.ca/cropprot/prodguide.htm).





## Disposal of pesticides and containers

---

The B.C. Ministry of Environment has responsibilities for the protection of the environment and for related disposal practices. Consult with the nearest office of this agency for information on disposal.

WorkSafeBC's mandate includes the protection of workers during and following the disposal process. The following sections outline safe disposal practices for pesticides and containers.

### Unused pesticides

- Carefully figure out your pesticide requirements to ensure minimal waste. Unless they are very old or deteriorated, unused pesticides should be used or recycled as long as it is legal to do so.
- Pesticide wastes should be properly disposed of at a special waste management facility. Disposal of large quantities of special wastes from commercial firms or farmers should be arranged through the firms that provide this service. Requests can be referred directly to such companies or to the Ministry of Environment.
- It is unsafe to dispose of pesticides or other wastes such as rinses from spray tanks in the catchment area of water sources such as dugouts and wells. Serious contamination of drinking water may result.

### Pesticide containers

- When empty, immediately rinse glass, plastic, and metal containers using the triple rinse or jet rinse techniques:
  - **Triple rinse**  
Rinse container with the appropriate solvent, usually water. Fill the container about one-quarter full, replace closure, shake and pour the rinse water into the spray tank, and drain thoroughly. Repeat twice.
  - **Jet rinse**  
Invert the container and drain into the spray tank. Puncture the bottom area of the container with the jet rinse and spray for 30-60 seconds.
- Multiple washes do *not* completely clean residues from pesticide containers. Follow Ministry of Environment requirements and recommendations to ensure that washed containers are either returned to the supplier or are destroyed and disposed of in an approved manner.







## Personal cleanliness and wash-up facilities

---

- Immediately cleanse any body area contaminated with pesticide. Wash hands and face after pesticides are handled and before break periods or lunch. Wash thoroughly when finished for the day, and change into clean clothing.
- Wash contaminated clothing before re-use. Hot wash temperatures of at least 60°C are advised. Bleach and detergent are particularly useful when washing clothing contaminated with carbamates and organophosphates. It is a good practice to wash clothing made of absorbent materials such as cotton *more than* once if heavily contaminated with pesticide. **Never** wash contaminated clothing with other laundry.
- Avoid eating, drinking, or smoking when working with pesticides.
- Make sure enough soap and water is available for routine cleanup. Shower facilities must be available for mixers, loaders, applicators, and flaggers to wash effectively at the end of the work period. Arrangements must be made to ensure that such workers have clean clothing and are provided with appropriate, clean protective equipment at the beginning of every work shift.
- Ensure that where persons could be exposed to chemicals, proper washing facilities are available, as required by sections 6.95 (Wash and shower facilities) and 5.82 (Employer's responsibility) of the Occupational Health and Safety Regulation.
- Ensure that emergency washing facilities are provided in the event of harmful contact with pesticides, as required by sections 5.85 to 5.96 of the Regulation. Various plumbed-in and portable systems for use at worksites are available. Some plumbed systems are shown in Figure 15.



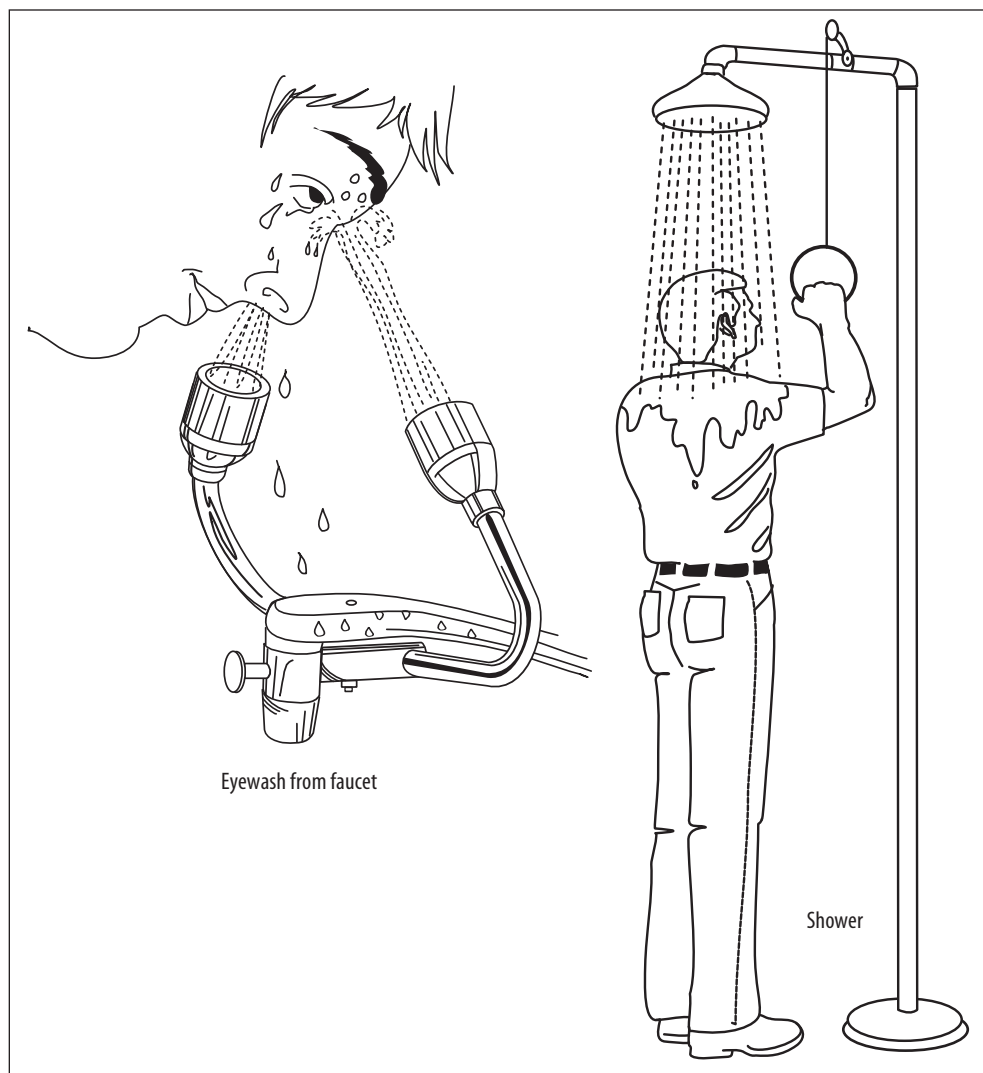

**Figure 15: Emergency wash facilities**







# 7 Precautions for specific pesticide applications

**This chapter includes the following sections:**

- Introduction
- Field and orchard application
- Landscape application
- Silviculture application
- Aerial application
- Structural pesticide application
- Fumigation
- Wood treatment







## Introduction

---

This chapter provides safety information for seven major types of application situations:

- Field and orchard
- Landscaping
- Silviculture
- Aerial application
- Structural pest control
- Fumigation
- Wood treatment

It aims to help applicators deal with some of the hazards specific to different types of applications. It is also a supplement to information found in the rest of the manual, particularly in Chapter 6.





## Field and orchard application

---

A proper pest control program must be well planned. The choice of control procedure is important. Both administrative control measures (such as crop rotation, moisture control, etc.) and biological agents (such as predator mites and parasitic wraps) may provide alternatives or supplements to chemical methods.

### Safe procedures for mixing and loading

- Before handling a pesticide, read the product label, consult the safety data sheet, and wear the right personal protective equipment. (See Chapter 6 for details.)
- Closed mixing and loading systems have been shown to reduce pesticide exposure. Commercial designs of closed systems are available, and the engineering principles are simple.
- Use a sharp knife or other cutting implement to open paper containers; do not tear them. Stand upwind while opening.
- Mix pesticides in good light and with adequate ventilation.
- To reduce dust exposure, pre-mix wettable powders with a small amount of water before adding to mixing tanks.
- Fill mixing tanks half full with water *before* adding pesticide concentrates.
- Pouring concentrates or slurries into large mix tanks may be dangerous because of the height of the tank opening. It is essential to keep pesticide containers below eye level to minimize the chance of splashes onto the face. Work platforms or pumping systems can help eliminate this hazard.
- Do not contaminate drinking or recreational water. Install an appropriate backflow preventer such as a check valve or air gap if filling water is drawn from a drinking or irrigation water system or from a surface water source. (See Chapter 6 for details on backflow prevention.)
- Make sure that lids are secured on all pesticide mix tanks after filling. If a tank is not provided with a lid (for example, if used in a dipping operation), the tank must be enclosed with walls, fences, or guardrails or other means to prevent any person from accidentally falling in.

### Safe procedures for application

- Before applying pesticides, read the product label and material safety data sheet, and wear the right personal protective equipment. Minimum requirements may include chemical-resistant boots, raingear, hat, gloves, goggles, and an effective, approved respirator. (See Chapter 6 for details.)



- 
- Ensure pesticide application equipment is calibrated and in safe running condition before use. Calibration instructions are provided in Chapter 10 for backpack units, boom applicators, air-blast sprayers, and granule spreaders. Maintenance checkpoints should include pressure hoses, pressure regulators, power take-off (PTO) guards, nip point guards on belt drives, and fan guards on air-blast sprayers.
  - Before applying pesticides, ensure that appropriate warning signs are posted at normal points of worker entry to the spray site, and take any other necessary measures so that pesticides are not a hazard to other workers. Notify neighbors so children and pets may be kept away from the treated area. (See Chapter 8 for details.)
  - Do not exceed recommended application rates. If those rates do not control a pest, consult with the appropriate authorities such as the B.C. Ministry of Agriculture, the B.C. Ministry of Environment, or Agriculture Canada.
  - Use minimum operating pressures. Recommended pressure ranges are 200–275 kPa (30–40 psi) for herbicides and 500–2,100 kPa (75–300 psi) for insecticides or fungicides.
  - Use the proper nozzle for the job. Cone spray patterns are not meant for herbicides. Nozzle and swirl plate dimensions are particularly important in low-volume air-blast operations. Specialty anti-drift nozzles are available for spray applications. Other useful design features include quick-release nozzles and anti-drip valves. (See Chapter 5 for details.)
  - Use nozzles with the minimum possible spray angle. The wider the angle, the greater the possibility of drift.
  - With boom applicators, use the minimum possible boom height to minimize the potential for spray drift.
  - Consider the use of wick applicators and similar devices to cut down on any potential for drift.
  - Do not spray pesticides at unsafe speeds. The Ontario Ministry of Agriculture provides recommended travel speeds for the tree fruit industry in its *Guide for Spraying Fruit Trees* fact sheet, which can be found at [www.omafra.gov.on.ca/english/crops/facts/00-035.htm](http://www.omafra.gov.on.ca/english/crops/facts/00-035.htm).
  - Do not misapply pesticide because of unnecessary overlap in spray patterns. Swath edges on grain crops, turfs, etc. can be marked with devices that apply materials such as aluminum particle suspensions, foam, or latex paints. Switching off the applicator while turning at the end of a spray swath can help avoid over-application of pesticides on the inner area of the turn.
  - Blank off any nozzles not needed.
  - Where appropriate, use thickening agents to reduce the likelihood of drift.







- As a general rule, do not spray if wind speed is more than 8 km/h (5 mph) or if air temperature is above 30°C. To minimize any contact with pesticide drift, wherever possible begin the application on the downwind side of the field, and proceed at right angles to the direction of the wind (i.e., cross wind). See Table 17 for information on assessing wind conditions.
- If there is a chance that water spray may contact exposed electrical equipment (for example, when air-blast operations are carried out near stingers), take appropriate precautions. Refer to the next section, **Landscape application**, for details of safety procedures.
- After the application of pre-emergent herbicides on dry soil, wetting the soil periodically can help ensure that pesticide-contaminated dusts are not produced.
- With backpack units:
  - Wherever possible, place the unit on a waist-high surface such as a table, tailgate, etc. before slipping into the shoulder straps to minimize the chance of spill while putting the unit on. Take the unit off using a similar procedure.
  - Always walk upright to avoid any leakage through filling caps or air-bleed holes.
  - *Never* walk backwards while carrying such units.

**Table 17: Wind observation chart**

Beaufort wind scale code number	Wind velocity (km/h)	Wind description	Observation
0	Less than 2	Calm	Leaves hang motionless. Grasses motionless.
1	2–5	Light air	Leaves and grasses move gently.
2	6–10	Light breeze	Very small branches move. Leaves move rapidly. Tall grasses swaying.
3	11–19	Gentle breeze	Smaller branches move. Billowing fields.
4	20–29	Moderate breeze	Large branches move.
5	30–38	Fresh breeze	Large branches move strongly. Small trees (less than 5 metres high) move.
6	39–50	Strong breeze	Large trees (higher than 5 metres) move.
7	51–60	Moderate gale	Large trees move vigorously.





## Landscape application

---

### The nature of the hazard

Landscape pesticide application programs may be used in parks and school grounds, along road rights-of-way, on cemetery lawns, golf courses, and the like.

Some hazards that may be of particular concern include

- Large quantities of chemicals may be used, and safe storage requirements may be extensive.
- Spray programs may be carried out in densely populated areas and require that particular steps be taken to ensure that pesticides do not drift onto non-target areas.
- Road right-of-way spray programs may expose workers to traffic dangers.
- Pesticides may be applied near sources of electrical power (for example, if used in a tree pest control program adjacent to a power line).
- Workers not involved with the pesticide program may work in treated areas following application. Member of the public may be involved in re-entry to treated public areas.

### Safe work practices

All general procedures for the safe use of pesticides found elsewhere in this manual apply to the landscape industry. In addition, the following specific precautions are emphasized.

#### Alternatives to pesticides

In some cases, alternatives to chemical pesticides may help control landscape problems and may be less hazardous to workers. Techniques such as mow strips, turf aeration, particular mowing heights, and altered fertilization patterns have been found helpful in some programs. Consult with pest control authorities for further information.

#### Pesticide storage

Some landscape pesticide application programs may require large storage facilities, up to warehouse size.

Facilities must comply with all requirements of regulatory authorities regarding construction, lock-up, etc. See Chapter 6 for information on storage.





---

### **Anti-drift measures**

To help ensure the safety of other workers and the general public, it may be appropriate to use stringent anti-drift measures such as

- Shrouds over boom applicators
- Enclosed spray rollers
- Bivert spray systems
- Rope-wick applicators

### **Traffic control measures in road right-of-way spray programs**

Workers involved in weed control or other spray work along or near road rights-of-way must be protected against traffic hazards, as required by Part 18 (Traffic Control) of the Occupational Health and Safety Regulation. Safe procedures include

- Choosing periods of low traffic volume for the spray program wherever possible.
- Providing an effective means of traffic control whenever the movement of traffic may cause danger to workers. Dangerous situations include those in which
  - Working equipment blocks all or part of a travelled roadway
  - Workers or equipment are employed on a travelled roadway over the brow of a hill, around a sharp curve, or at any other location where oncoming traffic could be dangerous to workers
- Using warning lights, signs, cones, flagpersons, or other appropriate traffic control measures, as outlined in Part 18 of the Regulation.

### **Application near electrical power lines and equipment**

Sources of electrical power may present a hazard, particularly when water-based formulations are sprayed nearby. This could occur, for example, when vegetation is sprayed near power lines.

The best safety procedure is to set up the spray program so that spray does not make contact with energized electrical equipment. If this is not feasible and you have doubt about the safety of an application, consult with the power utility provider.

Ensure that all work activity, including minimum distances from conductors, conforms with the requirements of Part 19 (Electrical Safety) of the Regulation and with the requirements of the power utility provider.





---

### **Worker re-entry to treated areas**

Instances may arise where workers are expected to enter a treated area following the pesticide application. Adequate restricted entry signs, procedures, and personal protective equipment must be used as specified in Chapter 8.





## Silviculture application

---

Silviculture is the practice of controlling forest establishment, composition, and growth through

- Seed and seedling forest regeneration
- Growth control (thinning and bush elimination)
- Protection of grown stands against insects and disease

Pesticides are used in some aspects of silviculture operations.

### The nature of the hazard

Herbicides and fungicides, which are generally not as acutely toxic as insecticides, are used more often than insecticides in silviculture pesticide programs. However, silviculture work may involve a number of hazard issues such as

- The need for temporary or mobile pesticide storage and mixing facilities, and the remoteness of such facilities from piped water supplies
- Application of pesticides far from emergency facilities such as hospitals and fire departments
- Application of concentrates
- Use of application equipment and personal protective gear in rugged terrain, which may cause rapid wear and tear
- Potential exposure of non-applicators to pesticide residues or other consequences of the pesticide program
- Residues in treated areas, which may pose a hazard to people who enter the area after treatment

### Safe application practices

All procedures for the safe application of pesticides found in this manual apply to silviculture. In addition, the following specific points are emphasized:

#### Biological and cultural controls

The use of biological controls as alternatives to chemical pesticides has been particularly successful in silviculture. Biological controls may in some cases provide a less hazardous alternative to chemical applications. Cultural methods such as disease-resistant planting stock, burning, and scarification may also help reduce the need for chemical programs.





---

### **Remote location precautions**

Pesticide application programs in remote locations must make particular provision for

- Procedures for checking the well-being of workers assigned to work alone or in isolation, as required by Part 4 (General Conditions) of the Regulation
- Proper training in all emergency procedures, such as first aid, spill control, and firefighting
- Adequate emergency facilities, including first aid kits as well as emergency washing and spill cleanup equipment

### **Vehicle design**

If vehicles in remote locations serve as mobile pesticide storage facilities, design features must include

- Locked pesticide storage compartments
- Separation of pesticides from passenger areas, food, and protective gear
- Containment of pesticides in case of vehicle accidents
- Wash-up facilities where necessary

Refer to Chapter 6 for detailed information on mobile pesticide storage facilities.

### **Size of concentrate containers**

Smaller containers can be handled more safely than larger containers. Containers in the range of 5 to 25 litres (1 to 5 gallons) may provide a reasonable compromise between safety and volume needs.

### **Mixing and loading area**

Ensure that the central mixing and loading area is provided with

- An adequate supply of water for cleanup and emergencies.
- Adequate equipment for dealing with spills. Recommended containers include metal drums with lids that can be securely attached. Drums must be labeled with the name of chemical contents.
- Adequate separation from eating areas. A distance of seven metres may be enough if the mixing area is downslope and if there is little likelihood of drift from mixing and loading procedures. Otherwise, longer distances may be required.





---

### Personal protective equipment

Wear personal protective equipment to match the hazard.

- **Footwear**  
Always wear chemical-resistant footwear, even for hack-and-squirt or fall-and-squirt applications.
- **Hand protection**  
Cloth gloves are *never* an adequate substitute for chemical-resistant gloves in liquid applications. The use of disposable gloves inside an outer pair of chemical-resistant gloves has been associated with substantial reduction of pesticide intake by B.C. hack-and-squirt applicators.
- **Eye protection**  
Chemical-resistant goggles or other appropriate eye protection must be used whenever the eyes may be exposed to chemicals. Eye exposure is a particular concern in mixing and loading procedures, and in foliar applications.
- **Protective clothing**  
When hand-held applicator bottles are used in hack-and-squirt applications, coveralls may provide sufficient protection. However, rain pants and at least a chemical-resistant vest are likely necessary if a backpack unit is used. Protective clothing must be sufficient to prevent pesticides from wetting through.
- **Respiratory protection**  
Respiratory protection may be unnecessary with some conventional hack-and-squirt applications. However, respirators are an essential part of many foliar spray programs and may be required for fall-and-squirt devices (such as brush-trimming saws equipped with herbicide applicators) when the devices are used for trimming above waist level.

### Equipment maintenance

When working in rugged terrain, ensure that hazard points on all application equipment are inspected daily. Hose lines and hose connections on devices such as backpack sprayers, hypo-hatchets, and brush-trimming saws with pesticide applicator units are particularly subject to wear.

All personal protective equipment and clothing must be cleaned daily and checked frequently for wear.





## Application practices

In hack-and-squirt or foliar application, safe practices include

- Minimizing quantities of pesticide carried to help reduce hazard in case of accidental spills.
- Choosing safe, durable application equipment. For example, some of the spray applicators available for use in hack-and-squirt programs are subject to leakage or other malfunctions. On the other hand, designs have been developed that feature closed loading systems and durable trigger assemblies.
- Applying pesticides at recommended rates. If recommended practices do not control a pest, consult with the appropriate authority, such as the Ministry of Forests or Ministry of Environment.
- Maintaining required no-spray buffer zones around streams or standing water.
- Where feasible, arranging work so that workers do not have to pass through previously treated areas. If that is not possible, workers must wear the protective equipment necessary to prevent skin contact with treated foliage.
- With hack-and-squirt applications, making cuts deep enough to hold chemical and minimize drip. Make all cuts around the circumference of a tree **before** applying herbicide. This procedure will help minimize the likelihood of splashback.
- Using proper procedures with backpacks. Whenever possible, don and remove the unit using an elevated surface such as a table, tailgate, etc. Always walk upright. Never walk backwards.

## Communication

When pesticides are applied to locations or tree stock that will later involve other workers who may be exposed to hazardous levels of pesticide residues, those workers must be informed by signs, or similar means, of the nature of the pesticides, their harmful effects, and safe work procedures.

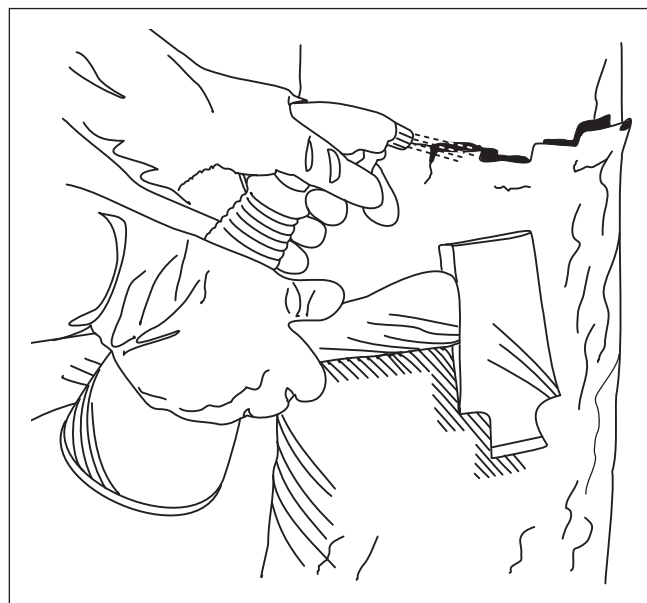

**Hack and squirt**

### Note

The refrigeration of seedlings will generally slow the rate of decomposition of pesticides previously applied to seedlings.

Safe re-entry into forests in which herbicides have been applied may be a concern long after the chemicals have disappeared. Trees treated with herbicide will eventually weaken and may become a safety hazard (due to falling limbs, etc.). Necessary safety measures may include posted warning signs and tree-falling programs.







## Aerial application

---

*Note: The requirements for the operation of aircraft fall within federal jurisdiction. WorkSafeBC's mandate extends only to the protection of workers at workplaces being sprayed from the air, and includes any flagpersons who would assist pilots in positioning their spray runs. Information in this section that is related to aircraft operation is provided for information only.*

### **The nature of the hazard**

Aerial spraying can be an efficient means of applying pesticides in circumstances where access on the ground is difficult. However, it can be hazardous. Particular safety concerns include

- Structural safety of the aircraft.
- Prevention of pilot fatigue.
- Prevention of any pilot exposure to pesticides. Even minor poisoning symptoms such as blurred vision and impaired reaction time interfere with the ability to fly safely.
- Minimization of flying hazards at the application site.
- Protection of flagpersons.

It is essential that the pilot and ground crew undergo rigorous standard procedures training. This includes flaggers or other workers at the spray site.

The following sections provide information on equipment design and work procedures, and are meant as a supplement to safety information that appears elsewhere in the manual.

### **Equipment design and maintenance**

- All aircraft used for the application of pesticides must comply with the design and licensing requirements of Transport Canada.
- A safe pilot restraint system includes a seat belt, shoulder harnesses with inertial reel, and a crotch strap to prevent submarining (sliding forward under the seat belt).
- To reduce the likelihood of spray drift, four design features should be considered:
  - Spray boom lengths should be selected and installed so as to minimize drift. Spray booms on single-engine, fixed-wing aircraft that extend past three-quarters of wing length may increase the drift potential due to wing-tip vortex effects.





- 
- Drift potential varies with droplet size. Nozzle orientation to the direction of flight is important for droplet size control. Droplet size increases and drift potential is reduced as nozzles are angled back from the direction of flight.
  - Spray drift varies dramatically with wind speed. Smoke-generating devices mounted on the aircraft can aid in wind speed evaluation. The **Wind observation chart** on page 136 may also be helpful.
  - Positive nozzle shut-off devices eliminate drip upon completion of a spray swath. Three designs are available:
    - Diaphragm check valves
    - Ball check valves
    - "Suck-back" connections on the pumpAll three safety devices need regular maintenance for proper operation.
  - A valuable safety feature is an audio communications system between the pilot and loading site personnel or flagger.
  - It is a safe practice to shield flexible hoses carrying liquid pesticides under pressure where they pass through the cockpit of an aircraft.
  - Equipment should be thoroughly checked before application work. Leaking tanks, hoses, couplings, and nozzles can all lead to pilot exposure to pesticide.
  - Calibrate the spray system before application. For calibration procedures, see Chapter 10.
  - Keep windshields clean.
  - **It is unsafe for pilots to carry out any maintenance procedure or loading operation that may result in exposure to pesticide.**

## **Safe practices for pilots**

### **Personal protective equipment**

#### *Respirator*

Substantial levels of pesticides can develop in the cockpit, particularly in calm weather or in case of ground-level temperature inversions, which often occur at dawn. Pilots should use respirators that provide a safe quality of air during spray application and at any other time when there is exposure to pesticide air contaminants in the cockpit.





---

### ***Protective clothing***

Pilots should wear protective garments during any flight in which pesticides are applied. Garments should be chemical resistant and flame retardant. Flammable materials such as polyester, acetate, or acrylic should be avoided. Garments made of wool, cotton, or flame-retardant synthetics are preferred. Fabric should have a smooth, tightly woven finish.

### **Mixing and loading procedures**

It is unsafe for pilots to mix and load pesticides. Unless a closed mixing and loading system is used, the pilot must leave the cockpit and stand at a safe distance upwind during loading operations. It is unsafe for aircraft engines to be in operation during loading. Appropriate backflow prevention devices must be used when drawing mix water from piped systems or surface water bodies.

### **Ferrying procedures**

Pilots should not prime application equipment or test flow rates between the airstrip and the area to be treated. Priming and testing should be done with water only and, where possible, on the ground.

### **Swatch marking systems**

Human flaggers are subject to a high potential for pesticide exposure and should not be used unless necessary. Alternatives include

- Permanent flags or similar indicators set in a visible location near the area to be sprayed. This method is useful if the area is to be treated several times during the season.
- Temporary markers such dyes or balloons.
- Automatic flagging systems. These devices use weighted streamers released by the pilot to mark spray swaths.
- Aerial photographs and landmarks.

If flaggers are used, take precautions to ensure their potential for exposure is minimized.

### **Daily cockpit time**

Early morning and late afternoon spray schedules make for long duty days. Daily cockpit time should be specified to help prevent pilot fatigue, and rest facilities should be provided.





---

### **Pesticide storage and container disposal**

Pesticides kept at any flight strip should be stored in a safe manner. In some cases, mobile storage facilities such as those described in Chapter 6 may be appropriate. Do not leave empty pesticide containers at flight strips after an application program is completed.

### **Safe practices for flaggers**

- Because of their high potential for pesticide exposure, flaggers may be required to wear substantial protective equipment including respirator, impervious hat or hood, suit, gloves, and boots. It is necessary that a seal be provided between gloves and the sleeves of the spray unit. Several sealing devices are marketed for this purpose.
- Warn all people who may be exposed to pesticide drift to move to a safe distance.
- When the aircraft is lined up, and well before the aircraft reaches your work area, move over to the next position.
- Never turn your back on an oncoming aircraft.
- To protect others, stay at the site until the application is complete.

#### **Note**

Part 29 (Aircraft Operations) of the Occupational Health and Safety Regulation includes a requirement for personal protective equipment for flaggers.





## Structural pesticide application

---

The structural pest control industry is largely concerned with insect and rodent pests that may be present in space-enclosing structures such as warehouses, restaurants, food storage facilities, and homes.

### **The nature of the hazard**

The hazards associated with structural pesticides can depend on the type of pest controlled. For example, a number of the wood decay insect control agents can be persistent. Control agents for food-storage pests include the highly toxic fumigant gases. Control agents for fabric pests and parasitic pests tend to be of low to moderate acute toxicity and of relatively short persistence. On the other hand, many rodenticides are highly toxic.

Some of the major hazard concerns in the industry include the following:

### **The length of exposure of pesticide applicators**

An applicator may work 6 to 12 application sites per day throughout much of the year.

### **Transportation and storage difficulties**

Applicators often work from vehicles such as compact trucks in which pesticides, application equipment, and personal protective gear are stored. It is important to prevent inhalation of pesticide by the driver, pesticide contamination of personal protective gear in the vehicle, and spillage of pesticides on workers in case of a vehicle accident.

### **Communication**

Communication between the applicator and the workforce at the site of application may be difficult. Applicators often work at jobsites when other workers are not present.

### **Safe work practices**

All procedures for the safe application of pesticides found elsewhere in this manual apply to the structural pest control industry. In addition, however, the following specific points are emphasized:





---

### **Alternatives to pesticides**

A number of non-chemical strategies are available, including

- Habitat management
- Physical controls
- Pheromones for monitoring or mass trapping
- Biological control agents

For details, contact agencies such as the Ministry of Environment.

### **Transportation and storage**

Vehicles that hold pesticide on a more or less continuous basis should be considered as **mobile storage facilities**, and appropriate precautions need to be taken. Refer to Chapter 6 of this manual for more information.

### **Personal protective equipment and clothing**

Using the information provided in Chapter 6 of this manual, match protective equipment to the hazard encountered. The structural pest control industry, in particular, should note the following:

- Fumigants, fogs, and dusts represent the highest inhalation hazards. It is unsafe to apply any of these materials without respiratory protection.
- Because gloves are donned and removed so frequently in a typical workday, it is important to minimize skin contact with the contaminated outside surfaces of gloves. Three suggested alternatives are:
  - Wash exterior of gloves before removal.
  - Wear gloves large enough for easy removal.
  - Wear a pair of light disposable gloves inside the outer gloves. Discard the disposable gloves after each use.
- Keep spare clothing in case of contamination.
- Do not place contaminated protective equipment and clothing in the passenger compartment. Contamination of upholstery can result.
- Avoid placing respirators on the dashboard. Ultraviolet light will cause premature deterioration of rubber parts.

### **Communication with the workforce at pesticide application site**

All workers on site, or who may later enter the site, and who may be exposed to harmful levels of the pesticide are to be notified beforehand of

- The pesticide
- The nature of its harmful characteristics
- Precautions required for safe work





---

Techniques for providing information to the local workforce include

- Product hazard information on call records or other invoices which are filled out at the time of pesticide application
- Warning signs at entrance areas where pesticides have been applied
- Maps showing locations of application

### **Worker check systems**

Because structural pest applicators often work alone, a worker check system meeting the requirements of Part 4 (General Conditions) of the Regulation is needed.

### **Safe application practices for different formulations**

#### *Dusts*

- Ensure all gun connections are leak-proof.
- Ensure adequate respiratory protection is used, particularly for overhead applications.
- Watch for cracks in the casing of metal applicators. Eliminate or repair defective equipment.
- Avoid contamination of food at the application site.
- Non-combustible dusts can be applied near electrical units, but ensure that electrical contacts are not fouled. Insulate metal spouts of dusters with plastic or rubber tubing to avoid electrical shock, or use dusters fitted with plastic or fibreglass spouts.
- When dusts are applied to cracks and crevices, limit the pressure on the duster to minimize blowback, and remove or brush into cracks any dust remaining on exposed surfaces.
- If the dust is combustible, put out all flames and pilot lights, and shut down spark-producing equipment in the treated area.

#### *Liquid spray applications*

- Shake hand spray equipment containing emulsions and wettable powders before starting each job. Agitate wettable powder formulations often during application.
- Apply pesticide at low pressure to prevent back-splashing. When treating exposed surfaces, use light applications to prevent runoff. Recommended pressures are 20 psi (1.4 kg/cm<sup>2</sup>) for crack and crevice treatments, and 30–45 psi (2–3 kg/cm<sup>2</sup>) for fan sprays.
- Wipe up and, if possible, decontaminate all spills and splashes immediately. Dispose of soiled towels and rags safely.





- 
- With compressed-air hand-held tanks, always place applicator gun in the support mount on the side of the tank after each use.
  - A safe practice is to stamp nozzle codes *on the side* of the multiple nozzle heads so that nozzles can be set when viewing the assembly from the side.
  - Do not apply water-based pesticides near hazard points in electrical circuits.
  - Do not apply oil-based or other flammable pesticides near sources of ignition, such as pilot lights of stoves and gas refrigerators.

### ***Bait programs***

Tamper-proof, enclosed bait boxes are far less hazardous than open boxes. It is a safe practice to provide warning labels on bait stations.

Place bait boxes away from locations of work activity, in areas inaccessible to pets and children.

When the baiting program is completed, collect all accessible baits and containers, and safely dispose of used material.

### ***Fog applications***

Fogs are composed of very tiny, airborne liquid droplets generally less than 20 microns in diameter. They are produced from compact applicator units that atomize relatively small quantities of pesticide into an air stream.

**Thermal foggers** inject oil-based liquid formulations onto a heated surface or into a heated air stream. **Cold foggers** atomize unheated pesticide concentrates.

While thermal foggers represent a considerable flammability hazard, cold foggers can be hazardous due to the use of concentrates and the fact that the aerosol cloud is less visible than a thermal fog.

Safe practices include:

- Before fogging, ensure all workers other than the applicators are out of the area to be fogged, adequately secure all entrances, and post necessary warning signs.
- For thermal foggers, use only those diluents recommended by the manufacturer. The National Pest Control Association has recommended that the diluent **flash point** be at least 22°C (40°F) higher than the temperature of the fogging area. The flash point of a liquid is the lowest temperature at which the liquid gives off enough

#### **Note**

Bait programs are subject to specific requirements in sections 6.98 and 6.99 of the Regulation. The requirements address the safety of the applicator and of other workers.







---

vapor to produce a flame when a source of ignition is brought close to the surface of the liquid. For example, the flash point of xylene, a common diluent for emulsifiable concentrates, is 32°C. The flash point of kerosene, a diluent that may be used with thermal foggers, is in the range of 43°–72°C. Eliminate all sources of ignition.

- Close off all openings that lead to work areas outside the area being treated.
- Plan the application route through the building to provide for movement from remote locations toward exits.
- When starting a fogger indoors, select a location that is relatively open. In tighter spaces, pesticide concentrations can build up in the air and on nearby surfaces, resulting in a higher risk of exposure.
- After fogging is completed, do not permit re-entry until a safe period of time has elapsed and the area has been thoroughly ventilated.

#### ***Fumigants***

Refer to the next section of this chapter for information.

#### ***Re-entry to treated areas***

See Chapter 8 of this manual.





# Fumigation

---

Fumigation is the act of releasing a toxic chemical in such a way that it reaches the target organism wholly or primarily in the vapour or gaseous state.

Any material applied as a wettable powder or mist and which does not evaporate prior to contact with pests is technically not a fumigant.

Fumigants are used primarily in the agricultural and structural pest control industries. There are two general types of fumigant formulations, each of which can be applied in three ways.

## Types of formulations

### Vapourizing liquids and compressed gases

This type is marketed in pressurized containers or “smoke” generators. When applied, the fumigant vapours or gases are given off immediately. Examples of this type include methyl bromide and sulfuryl fluoride.

### Solids: granules and dusts

These are chemicals that emit fumigant gases only through chemical reactions with agents such as water. For example, the granular fumigant dazomet reacts with water to release gases such as hydrogen sulfide, methyl isothiocyanate, and formaldehyde. Likewise, aluminum phosphide granules will give off the fumigant gas phosphine after contact with water.

## Types of application techniques

### Soil fumigants

The subsurface soil application of either liquid or granular pesticides, generally for nematode control.

### Spot fumigation

The application of fumigants to mill, bakery, and processing machinery at specific injection points.

### Space fumigation

Application of fumigants to enclosed spaces such as warehouses, rail cars, shipping containers, greenhouses, grain bins, and beehives.





---

## The nature of the hazard

Fumigation is one of the most hazardous pesticide application techniques. Specifically:

- Fumigant gases and vapours are among the most toxic active ingredients used in the pesticide industry.
- Gases and vapours drift easily and can contaminate work areas far from the application site if adequate controls are not used.
- Fumigants are primarily an inhalation hazard. Respiratory protection is important.
- Generally, solid formulations are less hazardous than gas/vapour formulations. The hazards of space fumigation are generally higher than those involved with soil treatment.
- One safety feature of fumigation is that fumigants leave no long-term residues at the application site.

## Specific fumigant products

Table 18 provides a list of commonly used fumigant gases and vapours. Physically, these products can be divided into two groups depending on whether or not they boil above or below moderate temperatures (20°C to 25°C.) Low boiling point fumigants such as phosphine and methyl bromide are gases at normal temperatures. Higher boiling point fumigants such as dichloropropene mixtures exist as liquids that emit vapours. The higher the boiling point of a fumigant, the less easily it emits gas or vapour, and—all things being equal—the less hazardous it is to workers.

But all other things are not equal. While almost all fumigants are very toxic if inhaled, the permitted eight-hour limits in the air for various types range from 0.1 parts per million for chloropicrin up to 5 parts per million for sulfuryl fluoride.

Fumigants also vary a lot in their warning properties. Many fumigants have characteristic odours, but only a few have good initial warning properties that permit a worker to smell or sense the chemical well before it rises above exposure limits.





---

As discussed in Chapter 5, warning agents (odourants) such as chloropicrin are added to some fumigants such as methyl bromide to provide better warning properties. However, the effectiveness of the odourant will vary with the amount added and the period of time that elapses after fumigation. Studies suggest that chloropicrin may be far more easily absorbed by the materials being fumigated than methyl bromide, especially at low temperatures. As a result, in the hours following application, the warning properties of the chloropicrin may be reduced dramatically.

The same problem may exist for the fumigant gas phosphine, which is generated from the reaction of aluminum phosphide tablets with water. A study has shown that the strong initial odour produced can eventually disappear even when effective concentrations of phosphine are still present in the fumigation space. The initial low odour threshold (.02 ppm) of the gases given off by the tablets is considered to be due to trace impurities such as diphosphines, which can be more easily adsorbed by fumigated materials than phosphine itself.

**It is hazardous to use air-filtering respirators fitted with cartridges or canisters in work areas where dangerous levels of gases with poor warning properties may be present.**

Many fumigants are flammable. Sources of ignition must be controlled during application and in the period following, while the fumigant is still present.





**Table 18: Hazard properties of fumigants**

Fumigant	Maximum permitted level in the air (parts per million) <sup>1</sup>	Odour threshold (parts per million)	Odour warning properties	Odour description	Boiling point (°C)	Flammability	Field detector tube available?
Aluminum phosphide (see phosphine)							
Chloropicrin	0.1	1–2	Poor	Acrid, intensely irritating	112	Non-flammable	Yes
Formaldehyde	0.3 (1 ceiling)	1	Fair	Irritating, pungent	-19	Flammable	Yes
Hydrogen cyanide	4.7 ceiling	1–5	Fair	Bitter almond	25	Flammable	Yes
Methyl bromide	1	500	Poor	Chloroform-like odour at high concentration	4	Non-flammable	Yes
Phosphine	0.3	.02 <sup>2</sup>	Good/fair	Fish or garlic-like	-87	Very flammable	Yes
Dichloropropene	1	1	Fair	Sharp, sweet, irritating	96	Flammable	No
Sulfuryl fluoride	5	Odourless unless mixed with odourant such as chloropicrin	Poor unless odourant is added	Odourless unless mixed with odourant	-55	Non-flammable	Yes

1. The levels are eight-hour average exposure limits unless otherwise noted.

2. This odour threshold is due to impurities in the production of phosphine from aluminum phosphide tablets. A range of thresholds has been reported up to 2 ppm. Pure phosphine is considered to be almost odourless.





---

## Field methods of measuring fumigant levels

Portable field equipment is available for measuring air concentrations for most fumigant pesticides. Types of equipment include gas detector tubes, traditional thermal conductivity and halide meters, and more contemporary portable equipment based on systems such as electrochemical detection. Detector tubes have the widest application and are often effective in evaluating fumigant levels in concentrations near exposure limits.

### Gas detector tubes

These are small glass tubes filled with chemical material that change colour on exposure to various fumigant gases and vapours. Each fumigant requires a different detector tube. The tubes are designed to fit into small hand-operated pumps that draw specific amounts of air through the tubes. The amount of colour change in a tube provides a measure of the amount of fumigant in the air. Two types of pumps used are the bellows and piston models (a piston model is shown in Figure 16).

Gas detector tubes are available for all but one of the fumigants listed in Table 18. To use the tubes to best advantage, the following precautions should be taken:

- Carefully read the instructions provided with the tubes. Note if there are any other chemicals that may be in the air that would interfere with the measurement.
- Test the pump prior to use to ensure there are no leaks.
- Do not use tubes that have exceeded the expiry date printed on the package.
- Make several measurements to ensure that results are representative of the airspace being tested.

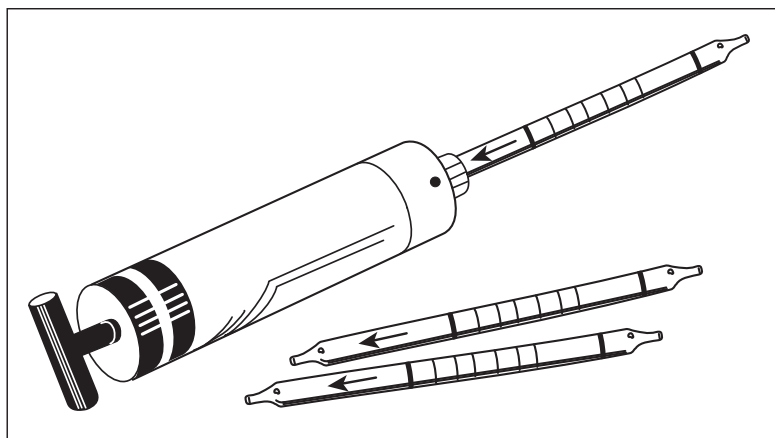

Figure 16: Piston gas detector pump and tubes

Gas detector tubes generally have maximum rated accuracies of  $\pm 25$  percent.

### Thermal conductivity meters

These devices are based on the principle that when electric current is passed through a wire, the temperature of the wire will be affected by the gas surrounding it. As the gas changes, the temperature of the wire changes. The temperature change in turn alters wire resistance, which can be





---

measured on a meter. Conductivity meters are more bulky than gas detector tubes, need frequent calibration, and are limited to the measurement of fumigants such as methyl bromide.

### **Halide leak detector (halide lamp)**

These devices work on the principle that a flame in contact with a clean copper filament will burn with a green to blue flame if the vapour of an organic halide such as methyl bromide is present in the surrounding air. As the concentration of the vapour increases, the colour changes from green to blue. Note: These meters are not highly accurate and must never be used to evaluate a flammable fumigant.

### **Newer technology portable detectors**

A range of portable equipment has been developed recently, based on systems such as electrochemical or photoelectric detection. Some devices are handheld, while others are larger in design. Accuracies can be substantial, and the devices are often intrinsically safe (i.e., they can be used in hazardous atmospheres).

## **Safe procedures with fumigants**

### **Information**

All persons who may be exposed to harmful levels of a fumigant are to be notified, *before* use of the substance, of its harmful characteristics and precautions required for safety.

### **Emergency procedures**

Before application, establish written emergency procedures to deal with situations such as pesticide poisoning and pesticide spills, and train workers in those procedures. When an applicator fumigates from inside enclosed spaces such as warehouses, vaults, or holds, it is essential to have a second person at hand who is trained and equipped to effect rescue.

### **Personal protective equipment**

#### ***Respirators***

Persons exposed to concentrations of fumigants in the air above permitted levels must wear adequate respiratory protective equipment. Cartridge respirators typically do not provide adequate protection.





---

Canister respirators may be adequate only in some situations where low levels of exposure are involved. **Canister respirators must not be used in situations that are immediately dangerous to life and health (IDLH).**

In high hazard situations when, for example, a person enters a confined space such as a fumigation chamber, storage room, etc. in which high levels of fumigant gases may be present, a self-contained breathing apparatus (or an airline respirator with an escape bottle) is required. Also, such respirators are the only sure protection when working with fumigants with poor warning properties.

#### ***Protective clothing***

Various combinations of chemical-resistant gloves, boots, pants, jackets, and eye protection should be used, particularly when workers may be exposed to fumigants in their solid or liquid forms.

#### **Worker checks**

It is not good practice to work alone when applying fumigants. Deaths due to fumigant exposure have been recorded for virtually all kinds of fumigation procedures. Worker check systems must be in place whenever required by Part 4 (General Conditions) of the Regulation.

#### **Sources of ignition**

If flammable fumigants are used, all sources of ignition at the worksite must be controlled. Ignition sources include burning cigarettes, gas-fired heaters, and electrical equipment.

#### **Space and spot fumigation practices**

Space and spot fumigation techniques are particularly hazardous because the fumigation is carried out in enclosed airspaces that may trap the fumigant for extended periods of time, and because of the possibility of drift to adjacent work areas not being fumigated.

#### **Note**

When handling methyl bromide, remove items such as rings and watches that could trap the fumigant against the skin. Prolonged contact of methyl bromide with the skin can produce severe blisters. Wear impervious clothing, gloves, and face shields (20 cm minimum) when there is any possibility of skin contact with liquid methyl bromide. Wash exposed skin immediately after methyl bromide exposure.

#### **Case example**

Forty-eight hours after application of methyl bromide to a warehouse, food-processing workers were poisoned, one severely, while at their workstations one floor below. Methyl bromide had escaped through an opening in the warehouse and drifted down through a feed hopper to the workstation.







---

Safe practices for space and spot fumigation include

- **Sealing**

Adequately seal the space to be fumigated against leakage through openings that lead to areas where unprotected workers may be present. Sealing materials include masking tape, heavy kraft paper sheeting, caulking compounds, plastic sealants, and heavy polyethylene sheeting. Sheeting of 4–5 mil thickness offers better tear resistance and is more impervious than thinner varieties.

- **Removal**

If adequate sealing cannot be ensured, two options are available: move unprotected persons who may be in the vicinity to a safe location, or move the material to be fumigated to a location that is a safe distance from people. For furniture and other items that can be moved, a means of ensuring safety is to provide treatment in an airtight fumigation chamber.

A properly designed chamber features a ventilation system that can be controlled from outside the unit. The chamber's walls should be sealed with a surfacing material to prevent absorption. Gasket material should be provided around the door and maintained in good condition.

- **Securing the fumigated area**

The entrances to a fumigated area must be barred before fumigation to prevent entry by unprotected persons, and adequate warning signs must be posted at all points of entry. (See Chapter 8.)

- **Fumigant application**

Wherever possible, introduce fumigant gas from a point outside the area being fumigated. In spot fumigation of machinery, it is a safe practice to apply fumigants first to application points furthest removed from the exit and then to work toward the exit.

- **Re-entry to the fumigated area**

See Chapter 8.

### **Safe soil fumigant practices**

Soil fumigants may be applied as

- Water-reactive crystals such as dazomet
- Liquids such as dichloropropenes
- Gases such as methyl bromide

Soil fumigation may be performed outdoors or in locations such as greenhouses.





---

While soil fumigation may often be less hazardous than space fumigation, it can still present a significant hazard, especially in enclosed spaces such as greenhouses.

#### **Case example**

In Belgium, a number of workers were killed while applying methyl bromide as a soil fumigant in a greenhouse.

In addition to all other necessary safety procedures, it is desirable with soil fumigants to

- Ensure that solid formulations (such as dazomet, which emits toxic gases on contact with water) are stored in dry locations.
- Use polyethylene or other gas-resistant sheeting wherever possible as ground cover to reduce emissions into the airspace above the treated soil. It is a safe practice to overlap sheets substantially at joints, to tape joints, and to secure edges (for example, with dirt or sand sprinkled on top of the sheets).
- Use caution when removing sheets, particularly for fumigants with higher vapour pressures such as methyl bromide. One study found that workers were exposed to levels of methyl bromide as high as 200 ppm during sheet removal one week after initial application.
- Use caution if cultivating soil that contains unreleased fumigant vapour. Mechanical agitation will contribute to vapour release.





## Wood treatment

---

### The nature of the hazard

Moulds and mildews can develop in damp materials such as freshly cut lumber and in unpainted wood such as fencing and foundation beams. In addition, some insects will attack wood, particularly if it is in deteriorated condition.

Wood preservatives are used to protect wood from the long-term effects of fungi and insects after installation, particularly where the wood can be exposed to damp conditions (for example, utility poles, marine pilings, bridge construction, and various structural applications). Antisapstain materials are intended to protect lumber from fungi that could stain it in the period following milling.

A variety of chemicals have been developed for use as wood preservatives and antisapstain agents. Examples include

- Ammoniacal copper arsenate (ACA)
- Chromated copper arsenate (CCA)
- Creosote
- Copper ethanolamine complex (ACQ)
- Pentachlorophenols
- Copper-8-quinolate (PQ8)
- TCMTB
- Propioconazole
- Zinc or copper naphthenate

Treatment chemicals have a wide range of toxicities, and some are corrosive to the skin. Also, in some treatment systems, acid formulations are used to help ensure that metal surfaces in lumber mill conveyer and feed systems do not stain the lumber.

There are a number of systems for applying wood preservatives and antisapstain agents. Some of the primary ones are listed on the pages that follow.



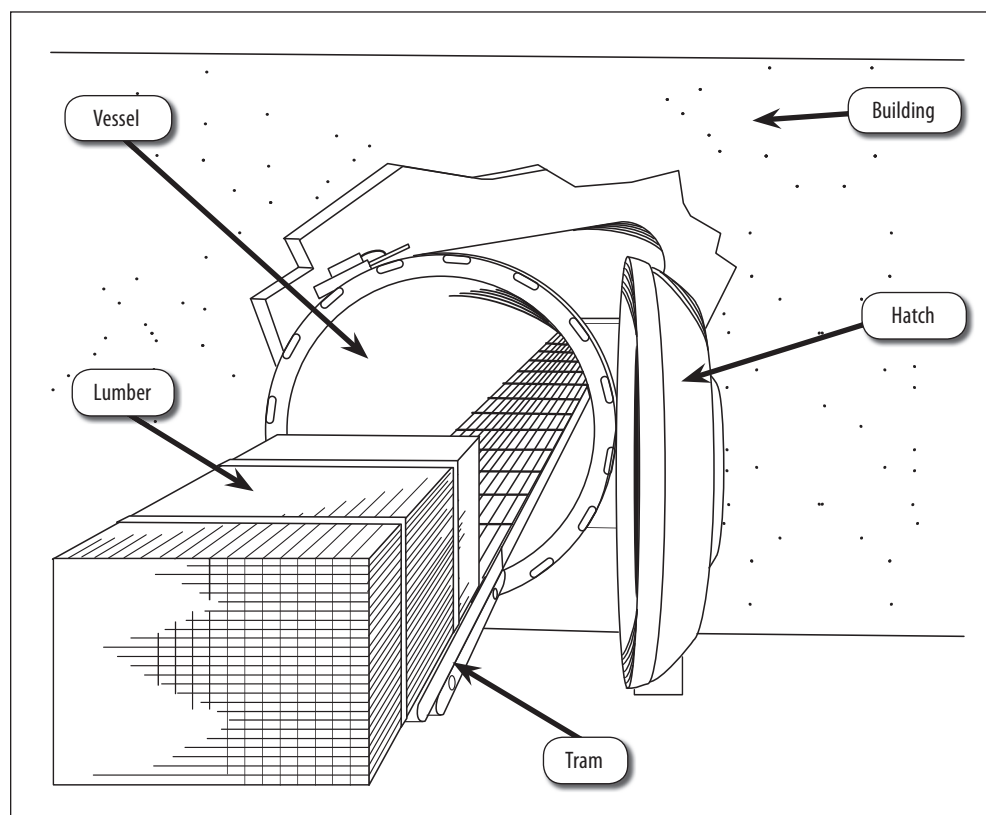

**Figure 17: Pressurized vessel used for applying wood preservative**

### **High-pressure treatment vessels**

This type of system is used for pressure treating lumber with wood preservatives. The vessels can be 30 metres or more in length, and are large enough in diameter to handle trams loaded with lumber. The trams are typically pushed into the vessels by on-site mobile equipment, and then pulled from the vessels after treatment.

Ports at one or both ends of the vessel provide access. The ports are sealed shut during the treatment. Hazard issues with this type of system include

- Exposure of the mobile equipment operator, particularly if it is necessary to enter the vessel to attach pull-out lines
- Contamination of areas outside the vessel

Other hazards include the pressures involved and any maintenance procedures that would require entry into the vessels.



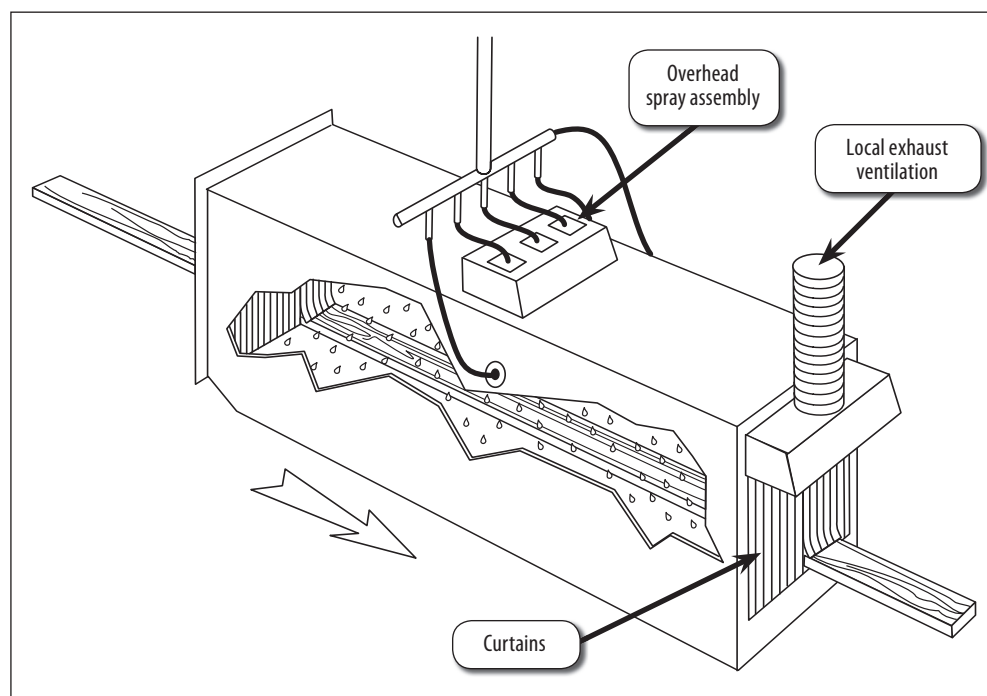

**Figure 18: Linear spray box treatment system**

### **Spray box systems**

In these types of systems, lumber is typically fed through a box and sprayed briefly with chemicals while inside. Spray boxes are often used for applying antisapstain agents during milling operations.

Three types of spray systems include

- Linear feed (where the lumber is fed through end to end)
- Transverse feed (where the lumber is fed through sideways)
- Car wash design

Hazard issues with spray boxes include

- Potential exposure of nearby workers to mists and vapours
- Chemicals dripping from the lumber after it leaves the spray area
- Handling freshly treated lumber on green chains and in sorting operations

### **Dip tanks**

In these operations, lumber is typically dipped into tanks for short periods using a mechanical system that forces the lumber below the surface of the treatment chemical. After raising the lumber out of the





---

tank, the system may include a means of tilting the lumber to help drain off excess chemicals. With dip tanks, bundles of lumber or other wood products can be processed in batches.

Hazards include the potential for accidental falls into open tanks, and entry into empty tanks for maintenance procedures. If the system is designed so that drip from bundles takes place at the tank, and treated bundles are processed without the need for further sorting, then the potential for other workers on-site to be exposed to chemicals is minimized.

### **Safe work practices**

The Regulation includes provisions that are specific to antisapstain agents. Examples include:

#### **Substitution**

The employer has an obligation to investigate antisapstain materials and, wherever practicable, substitute an alternate material if the hazards of the substitute are known and the risk to workers is reduced. If a new product is substituted, the material safety data sheet for the previous product will need to be kept as long as the workplace has not been adequately decontaminated of the previous material.

#### **Ventilation**

With spray box systems, the employer must install an effective local exhaust system to contain overspray and protect nearby workers. The system must ensure an inward flow of air into the box that is at least equal to the speed of the lumber on the outfeed conveyor. (Ventilation systems for transverse feed spray boxes will need to be particularly robust to meet these criteria because of the large infeed and outfeed areas involved.)

#### **Excess chemical controls**

The employer needs to ensure control measures are in place, such as mist eliminators, curtains on spray box openings, control of spray flows, and other acceptable means.

#### **Identification of treatment areas**

Treatment areas need to be clearly identified to workers, and entry into areas must be restricted to authorized personnel. The treatment area

---





---

includes any location that serves as a drip area following treatment. (Note: The requirements of the Regulation for warning signs and restricted entry intervals do not apply to antisapstain work unless the label specifies otherwise).

### **Other requirements**

The Regulation contains a number of other requirements that help ensure safety in wood treatment operations. For example, the requirements address

- **Mixing and loading systems**

The systems involved are typically fixed in place, and they must have

- Means of securing openings to prevent accidental worker entry
- Shut-off devices at the discharge end of hoses and pipes leading from mixing tanks

Closed mixing and loading systems help ensure safety.

- **Wash-up and emergency washing facilities**

Treatment materials may be irritating or corrosive to the skin, and may also involve issues of skin absorption and toxic effect.

- **Guards around the perimeters of areas such as dip tanks**

Tanks are typically more than 122 cm (4 ft.) deep and need to be provided with guardrails or other means of guarding.

- **Personal protective equipment**

The necessary equipment will vary with the job. For example, a substantial range of equipment, including respiratory protection, is likely needed for a worker who enters a pressurized vessel to attach a pull-out line. However, for a worker who handles treated lumber, the necessary measures would be less extensive, involving protection such as chemical-resistant gloves.

- **Confined spaces**

Some treatment vessels may be confined spaces. If it is necessary for workers to enter such spaces (for example, in maintenance operations), then the requirements of Part 9 (Confined Spaces) of the OHS Regulation would apply.

- **Safety in welding and similar operations**

Treatment chemicals need to be cleaned from metal surfaces before any welding, burning, or cutting operation is done on those surfaces.

- **Control of hazardous wastes**

In treatment areas, chemicals may drip onto sawdust or onto the surface of the ground. These wastes need to be properly controlled. Specialized waste service providers may be of assistance.





# 8 Protecting re-entry workers

**This chapter includes the following sections:**

- Introduction
- Warning signs
- Restricted entry intervals
- Entry procedures
- Exceptions









## Introduction

---

Protection of workers who enter spray sites is a vital part of a pesticide safety program. A review of compensation claims showed that 50 percent of claims involved non-applicators, including workers who re-entered the treated area.

If workers may be exposed to pesticide residues during re-entry to a treated area, then before re-entry, the employer must clearly communicate to workers

- Information about the pesticide
- The nature of its harmful effects
- Safety precautions to take

Three keys to the protection of workers who may re-enter a treated area are

- Warning signs
- Restricted entry intervals
- Entry procedures





## Warning signs

---

Warning signs are an important part of the information alert system in areas where pesticides have been applied.

Under the Occupational Health and Safety Regulation, before a moderately or very toxic pesticide or a fumigant is applied, the employer must ensure that

- Warning signs acceptable to WorkSafeBC are conspicuously posted at normal points of worker entry to the area to be treated.
- If a pesticide is applied in an enclosed space, all entrances to the space are secured to prevent unauthorized persons from entering.

Warning signs need to be of a design, construction, and durability to be clearly identifiable for the prescribed posting period, and must provide information in a manner that can be readily understood by workers.

Signs need to be kept in place for the period in which they apply (i.e., the restricted entry interval). In some cases, it may be appropriate to leave the sign in place beyond the minimum period (for example, if an allergenic pesticide such as alachlor or dichlorvos is involved), provided that the signage indicates the reason for continued posting.

Warning signs for protection against fumigants in enclosed spaces differ from those that are acceptable in other pesticide applications.

### Warning signs for fumigants in enclosed spaces

Fumigants in enclosed spaces can represent a severe inhalation hazard. To address the risk, an acceptable sign will need to display

- A skull and crossbones symbol
- The words DANGER, DEADLY FUMIGANT GAS, KEEP OUT in a language that can be readily understood by the workers, and in letters large enough to be read at a distance of 8 metres (25 feet)
- The name of the fumigant
- The name of the applicator
- Emergency telephone numbers for both day and night

Figure 19 provides an acceptable warning sign for fumigants in enclosed spaces.







**DANGER – PELIGRO**

**POISON GAS**



AREA UNDER FUMIGATION WITH  
**METHYL BROMIDE**

*PRECAUCION AL USUARIO: Si usted no lee Ingles, no use este  
producto hasta que la etiqueta le haya sido explicada ampliamente*

DO NOT ENTER/NO ENTRE

Fumigation Date \_\_\_\_\_ Time \_\_\_\_\_

Company Name \_\_\_\_\_

Business Address \_\_\_\_\_

Certified Operator in Charge \_\_\_\_\_

Telephone Day \_\_\_\_\_ Night \_\_\_\_\_

A typical fumigant prohibited entry sign that could be found on a shipping container. The sign includes cautions in Spanish.

**Figure 19: Prohibited entry warning sign**





**Note**

The obligation to post signs for moderately or very toxic pesticides is a minimum standard required by the Regulation. Employers may also post signs for the application of slightly toxic pesticides.

**Warning signs for other pesticide applications**

Warning signs for the application of moderately and very toxic pesticides, other than fumigants in enclosed spaces, must display

- The skull and crossbones symbol
- The word WARNING in a language that can be readily understood by workers, and in letters large enough to be read at a distance of 8 metres (25 feet)
- The name of the pesticide
- The date of application
- The date of expiry of the restricted entry interval
- Instructions to obtain permission to enter, if entry is needed before the expiry date

Figure 20 provides an acceptable warning sign to cover these circumstances.



**Figure 20: Restricted entry warning sign**



## Restricted entry intervals

---

Along with warning signs, the use of proper restricted entry intervals is one of the keys to the safe re-entry of workers.

A **restricted entry interval** is the length of time representing a period of precaution that must elapse after the application of a pesticide before an unprotected worker may be authorized to enter the treated area.

Such intervals are intended to provide time to permit a significant reduction in the potential for harm to workers. They help protect workers from risks such as contact with wet surfaces, dislodgeable residues, and toxic vapours in the initial period following application. Measures to protect workers, including the use of personal protective equipment, may be necessary even after the expiry of the interval.

Restricted entry intervals are not the same as **time-to-harvest (preharvest) intervals**, which are periods of time required between the last application of pesticide and the time of harvest. Restricted entry intervals are meant to protect workers, while time-to-harvest intervals aim to protect consumers.

Minimum restricted entry intervals for pesticides are determined, based on acute toxicity ratings and label information, as follows:

**Table 19: Determining restricted entry intervals**

<b>Pesticide</b>	<b>Interval (time after application of pesticide)</b>
Slightly toxic pesticides (oral LD <sub>50</sub> more than 500 mg/kg, or dermal LD <sub>50</sub> more than 1,000 mg/kg)	24 hours minimum (it may be advisable to allow 48 hours if the pesticide is applied as wettable powder)
Very toxic or moderately toxic pesticides (oral LD <sub>50</sub> of 500 mg/kg or less, or dermal LD <sub>50</sub> of 1,000 mg/kg or less)	48 hours minimum
Label states a longer period	As per label requirements

Increasingly, pesticide manufacturers are providing entry interval information on labels. In some cases, labels specify lengthy periods (in one case, 28 days). Where the label specifies that re-entry should not occur until the pesticide has dried, the actual time may vary depending on weather and other environmental conditions. In all cases, however, the minimum time periods are 24 and 48 hours, as specified on the first two rows of Table 19.



## Entry procedures

---

If, before the expiry of the restricted entry interval, the employer authorizes a worker to enter a field, building, or structure in which a pesticide has been applied, the employer must ensure that

- The hazards to workers have been assessed by a qualified person
- The worker is provided with and wears the proper personal protective clothing and equipment required by the Regulation
- The worker follows safe procedures

For example, if workers enter a sprayed area, they need to wear personal protective equipment that is sufficient to protect them from harm. A chemical-resistant jacket or respirator would probably not be necessary for safe re-entry to an area in which a low-volatility herbicide was applied to the soil. However, protective clothing and a respirator are likely required for safe re-entry to an orchard treated with a high-volatility insecticide.

Entry before the expiry of the restricted entry interval should be limited to the following circumstances:

- **No-contact entry**  
No-contact entry means that workers may be permitted to enter, provided they have no contact with anything that has been treated by a pesticide or is contaminated by a pesticide.
- **Specific duties of short duration**  
In this case, a worker may be permitted to enter to perform *specific duties of short duration*. These duties should not exceed one hour and should not involve hand labour that may cause substantial contact with contaminated surfaces. Acceptable duties include the operation, moving, or repairing of equipment (other than equipment related to the preparation and application of pesticide).

Apart from the issue of restricted entry intervals, if the employer authorizes a worker to enter a building or structure in which any pesticide, including a fumigant, has been applied, the employer must ensure that

- Where practicable, the treated area of the building is ventilated and the atmosphere has been tested or otherwise evaluated by a qualified person and declared safe to enter
- If a worker may be incapacitated after re-entry, provision has been made for rescue



## Exceptions

---

The Regulation states that in some circumstances of limited hazard, it may not be necessary to post warning signs or adhere to minimum restricted entry intervals of 24 and 48 hours.

These exceptions are permitted if

- Treated areas are clearly identified to workers
- The indoor space has been adequately ventilated
- Safe work procedures are followed (including adherence to restricted entry intervals on labels)
- A hazardous spill does not occur
- A qualified person inspects the area following application to determine compliance with requirements

Examples of exception situations include the following:

- In structural pesticide applications when
  - Small quantities of slightly toxic pesticides are applied in a manner that minimizes the release of aerosols and residues on work surfaces, or
  - Moderately toxic pesticides are applied in restricted exposure situations such as crack and crevice treatment
- Cases where an avicide, predicide, rodenticide, or insecticidal bait is used or applied in solid or liquid form, unless the pesticide label specifies otherwise. In these cases, necessary protective measures include
  - Following safe work procedures (including providing and using personal protective equipment, and providing adequate hand washing facilities)
  - Restricting application to areas not readily accessible to unauthorized persons and away from normal work areas
  - Providing information to any worker required to enter the treated area regarding the location and description of the pesticide and any associated device, along with the precautions that must be observed
- Antisapstain applications, unless the label specifies otherwise. In such cases, the area of application must be clearly identified to workers, and entry into the area must be restricted to authorized personnel.







# Emergency procedures

**This chapter includes the following sections:**

- Introduction
- Poisoning
- Fires
- Pesticide spills







## Introduction

---

Procedures must be established to address three basic types of possible emergencies: pesticide poisoning, fires, and spills. Written procedures for managing emergencies must be developed for each hazardous substance at a workplace, as required by section 5.2(c) of the Occupational Health and Safety Regulation.

Ensure that all supervisors and workers who work with or around pesticides are trained in these procedures, as required by sections 5.2(d) and 5.7 of the Regulation.

Notify WorkSafeBC immediately if an accident results in death or a critical condition, or in the event of a major release or spill of toxic material.

Pesticide spills must be reported to the Provincial Emergency Program.

**Emergency telephone numbers are provided on the last page of this manual.**





## Poisoning

---

Information in this section addresses first aid procedures, first aid kits, antidotes for poisoning, and cholinesterase tests.

Information to assist with developing first aid procedures may also be obtained from the *Occupational First Aid Reference and Training Manual*, the B.C. Poison Control Centre, and the material safety data sheet (MSDS). Contact information for the Poison Control Centre is found on the last page of this manual. The sample MSDS in Chapter 2 of this manual shows first aid information covered in Section 8.

### First aid procedures

The instructions below are arranged in the order of priority that should apply with most poisonings. Proceed through the necessary steps as quickly and as thoroughly as possible.

1. **Summon the first aid attendant** for your worksite as outlined on the posted written procedures for providing first aid. If the worksite does not require a first aid attendant, proceed with the following steps.
2. **Assess the condition of the person, and provide basic life support** as necessary.
3. **Do not leave critically ill patients alone.** Get someone else to arrange transportation to the emergency department of the nearest hospital. Do not delay transportation to the hospital.
4. **Obtain history of exposure** from worker or co-worker, and determine the likely route of entry—mouth, skin, or lungs.
5. **If the pesticide was swallowed by mouth, phone the B.C. Poison Control Centre** using the contact information provided on the last page of this manual.

The approach to treatment will depend on whether a patient is fully conscious or not.

#### *For treatment of a fully conscious patient*

If the pesticide is a corrosive substance (acidic or alkaline)

- Do **NOT** make the patient vomit
- Do **NOT** neutralize
- Dilute immediately by giving the patient 1 to 2 glasses of milk or water

If the pesticide is non-corrosive or is a hydrocarbon (petroleum product), Poison Control may instruct you to induce vomiting by the following method:

- Give 30 mL (1 oz. or 2 tbsp.) of syrup of ipecac orally. The dose for children under age 15 would be 15 mL (1 tbsp.).





- 
- Give 1 or 2 glasses of clear fluid (water or juice) 10 minutes after the ipecac is administered.
  - You may receive instructions to provide activated charcoal after the patient has stopped vomiting. The dose would be 50 g (2 oz.) diluted in 250 mL (8 oz.) of juice or water.
  - The Poison Control Centre may instruct you to use activated charcoal immediately. **Do NOT administer activated charcoal to a patient who cannot swallow due to a decreased level of consciousness.**

Patients who have ingested a hydrocarbon must be watched closely while they are vomiting to ensure that they do not inhale vomit into their lungs.

**Do NOT make the patient vomit if any of the following conditions exist:**

- The patient is too drowsy to sit up, has a decreased level of consciousness, or is convulsing.
- The patient has ingested corrosive acids or alkalis.
- The Poison Control Centre has not been consulted.

*For treatment of a patient with a decreased level of consciousness*

Provide basic life support as necessary, and arrange for transport to medical aid.

6. **If the pesticide was spilled or sprayed on a person's**

*Eyes*

- Wash the eyes with water at once.
- Use a clean stream of water. Keep the victim's eyes open, and wash for at least 30 minutes.
- Do **NOT** add cleaning agents to the eyewash. Use clean water only.

*Body*

- If the chemical is dry, brush it off before flushing the skin.
- Immediately wash the chemical off the skin with large amounts of water.
- Remove contaminated clothing.
- Do **NOT** contaminate yourself in the process.

**Do not neutralize corrosive poisons with acids or alkalis.** Instead, flush with lots of water, and if possible, continue flushing en route to medical aid.

7. **If the pesticide was inhaled into the lungs (dusts, vapours, gases)**

- Protect yourself with proper safety gear before attempting rescue, and carry the patient (do not permit walking) to fresh air immediately.





- Loosen all tight clothing.
  - If the patient has stopped breathing, start CPR.
  - Keep patient as quiet as possible.
8. **Keep the victim warm unless the pesticide increases body metabolism and temperature.** Examples of such chemicals include chlorophenate wood preservatives.
  9. **Accompany the victim to the hospital,** and do one of the following:
    - Bring along a copy of the material safety data sheet for the pesticide
    - Take the pesticide label with you if the MSDS is not available
    - Write down and bring along the name of the product, the active ingredient, and its concentration, along with the Pest Control Product (PCP) registration number from the label
  10. **Report the incident to WorkSafeBC** using the contact information provided on the inside front cover of this manual.

### In the Regulation

- **Section 3.16**  
**Basic requirements**  
<http://www2.worksafebc.com/publications/OHSRegulation/Part3.asp#SectionNumber:3.16>
- **Schedule 3-A**  
**Minimum levels of first aid**  
<http://www2.worksafebc.com/Publications/OHSRegulation/Part3.asp#Schedule3A>
- **OHS Guideline G3.16**  
**First aid assessment**  
<http://www2.worksafebc.com/Publications/OHSRegulation/GuidelinePart3.asp#SectionNumber:G3.16-1>

### First aid kits

The types of first aid supplies, equipment, and facilities required at a worksite vary depending on

- The number of workers per shift
- The level of risk of injury to workers
- The surface travel time from a hospital

The Regulation and the associated OHS Guidelines establish the basic requirements for first aid equipment and supplies. Refer to these resources to determine the requirements for your worksite.

The following items should be included in a first aid kit:

- Syrup of ipecac to induce vomiting
- Activated charcoal to absorb pesticide
- Plastic bottle of clear water to mix with charcoal
- Cups for drinking
- Sufficient clean water for flushing eyes and skin
- Pair of clean impervious gloves to prevent skin contamination of the person who administers first aid
- Antidotes for poisoning, where appropriate
- Copies of material safety data sheets for each pesticide used at the worksite
- System for communication to the B.C. Poison Control Centre

Medical oversight may be necessary to obtain some of the antidotes for poisoning.





---

## Antidotes for poisoning

Antidotes—agents that can be administered to the victim to actually counter the effect of poisoning—are available only for some pesticides, such as organophosphate and carbamate insecticides as well as cyanides.

### Organophosphate and carbamate insecticides

Two antidotes, atropine and 2-pralidoxime (2-PAM), can be used to treat the effects of organophosphate insecticides. Atropine is also useful for treating poisonings from carbamate insecticides and any other pesticides that cause a slowing of the heart rate. These antidotes are administered by trained medical personnel and are available at many hospitals.

### Cyanides

The first steps in treating cyanide poisoning depend on whether or not the affected worker is breathing.

- **If the worker is not breathing**, administer artificial respiration immediately and, if no pulse is present, apply cardiopulmonary resuscitation (CPR). Transport the patient to medical attention.
- **If the worker is breathing**, amyl nitrite may need to be administered by *trained* first aid personnel using the following procedure:
  1. Wrap a single ampoule of amyl nitrite in a gauze pad or handkerchief and break it.
  2. Hold the ampoule about 2.5 cm (1 in.) from the patient's mouth and nostrils for 15 seconds.
  3. Repeat this procedure at 15-second intervals.
  4. Break a fresh ampoule every five minutes.
  5. Administer amyl nitrite until four ampoules are used or medical attention is reached.

The use of amyl nitrite is only one stage of treatment. Contact the B.C. Poison Control Centre or a physician. Refer to the pesticide's MSDS for more information.

A complete discussion of the proper procedure for cyanide poisoning is provided in training materials for Level 3 occupational first aid attendants.







---

## **Cholinesterase tests**

Laboratory tests can be done to estimate the degree of poisoning of workers who are exposed to organophosphate or carbamate insecticides.

The analysis is done on a body enzyme called cholinesterase, which is affected by these two classes of chemicals. Initial tests establish baseline levels for workers. In the event of exposure, additional tests can be used to determine the extent of change to the baseline levels.

Cholinesterase tests can be useful as part of an ongoing health maintenance program for workers who may be exposed to organophosphate and carbamate insecticides, and in emergency situations. For more information, see the booklet *Working Safely with OPs*, which is available on the WorkSafeBC web site at [WorkSafeBC.com](http://WorkSafeBC.com).





## Fires

---

A pesticide fire is one of the most dangerous types of fires to fight because

- Smoke from pesticide fires likely contains levels of unburned pesticide.
- All pesticide fires produce acid gases that can irritate the lungs. Some acid gases, such as hydrogen sulfide and hydrogen cyanide, are very toxic to life.
- Many organophosphates can be converted in fires to more toxic chemicals called "oxons."
- At higher temperatures, containers of some pesticides can explode.

### General responsibilities

If the workplace is within the service area of a fire department, the employer must ensure the department is notified of the nature and location of pesticides and the methods to be used in their safe handling. Providing the fire department with material safety data sheets for the pesticides on site will assist with meeting this requirement.

Section 4 (Fire and Explosion Data) of the sample MSDS in Chapter 2 of this manual is intended for information that addresses

- The potential for fire or explosion
- The hazardous combustion products that could be present during a fire
- The means of extinction of the fire

Section 5 (Reactivity Data) provides additional information that may be of use. The employer must also ensure that workers who work with or near pesticides are instructed in the hazards of pesticides and the safety precautions to use with them, including emergency procedures in the event of a fire.

### If a fire occurs

First, evacuate people and animals who are downwind of the fire, and keep bystanders away. Call the fire department, and make it clear that it is a pesticide fire.





---

## Information for firefighters

The fire service develops procedures for fighting fires. The following information is provided for assistance in meeting that responsibility. It is good practice to

- Wear chemical-resistant gloves, boots, and full-body protective clothing. A self-contained breathing apparatus is essential for firefighters exposed to fumes and smoke.
- Wherever possible, fight fires from the upwind side.
- Wherever possible, use foam or carbon dioxide rather than water. Some pesticides can ignite or emit toxic gases on contact with water.
- Use soft streams of water like a fog so as not to tear open paper bags or break glass containers. Dusts from broken bags can be explosive.
- Periodically cool any metal or plastic pesticide containers to reduce the likelihood of explosion.
- Avoid dragging hoses through pesticide-contaminated water.
- If firefighters are exposed to smoke and other contact with pesticides, they should wash exposed body areas as soon as possible at the fire site. A major route of pesticide poisoning is through the skin.
- If the fire included organophosphate and carbamate pesticides, alert the nearest hospital to have cholinesterase tests and antidotes available. Immediately take any firefighting personnel suffering poisoning symptoms to hospital for treatment.
- Once the fire is out, apply decontamination procedures to contaminated land, all firefighting equipment, and personal protective equipment and clothing.





## Pesticide spills

---

### Equipment

Ensure that spill control and cleanup procedures are planned in advance, and that necessary equipment is available in the event of a spill or other release of pesticide.

The label and particularly the material safety data sheet for the pesticide are expected to contain information to assist with developing spill control measures. The sample MSDS in Chapter 2 of this manual shows leak and spill procedures as well as waste disposal under Section 7 (Preventive Measures).

Spill control and cleanup equipment should be available for use at sites such as storage/mixing and loading facilities. A minimum kit should include

- Personal protective equipment (for example, gloves, boots, and respirator)
- Absorbent material
- Neutralizing material
- Long-handled brush
- Shovel
- Waste-receiving container with lid

### Procedures

1. **First**, keep other people away from the spill. If the spill occurs on a roadway, prevent vehicles from travelling over spilled material.
2. **Before cleanup**, review the control procedures and put on the right personal protective equipment. If the spill is inside an enclosed area such as a room or shed, ventilate the area. At minimum, open doors and windows. If explosive levels of flammable materials may be present in the air, ensure the ventilation system is explosion proof.
3. **During cleanup, do NOT** wash away spilled material. This only spreads the pesticide. Use the B-A-N system:
  - **Barricade** or dike the spilled chemical to prevent its spread.
  - **Absorb** or soak up as much *liquid* material as possible.
    - Absorbents include clay, vermiculite, and cat litter. Commercial absorbents are also available that both absorb liquid and suppress vapours.
    - Flammable absorbents such as sawdust, rags, and paper are less desirable than non-flammable varieties.
    - With *dusts*, wet down before sweeping.



- 
- Dispose of the absorbent safely. A recommended practice is to place absorbent in sealed, watertight drums.
  - The Regulation requires workplace labels for containers of hazardous wastes. Consult the nearest office of the Ministry of Environment for information on waste disposal procedures.
  - **Neutralize** any remaining residues. If possible, use a long-handled brush to scrub the spill area to help minimize inhalation of vapours. Consult the pesticide label and MSDS to determine specific neutralization techniques. The following general comments will serve as guides:
    - Many organophosphate pesticides, such as diazinon and azinphos-methyl, can be detoxified with a mixture of washing soda (sodium carbonate) and bleach (sodium hypochlorite).

**WARNING:** Never mix bleach with acidic cleaning agents such as some janitorial cleaning aids. Do not use bleach to treat acidic pesticides such as glyphosate. Dangerous chlorine gas is given off when bleach is mixed with acidic materials.
    - Some carbamates such as carbaryl can be detoxified using caustic solutions such as washing soda (sodium carbonate), caustic soda (sodium hydroxide) or strong detergent.

**WARNING:** Many caustics are very corrosive to the skin, particularly the eyes. Wear appropriate protective equipment.





# 10

## **Maintenance and calibration of application equipment**

**This chapter includes the following sections:**

- The maintenance program
- Equipment calibration







## The maintenance program

---

An equipment maintenance program should be based on equipment hazard point (critical part) identification as outlined in Chapter 5 of this manual. A sample **critical parts inspection form** is provided on page 194 for possible use in the program.

The following sections describe components and procedures that an equipment maintenance program should include:

### Spray nozzles

Troubleshoot spray nozzles as required. **Never** blow out clogged nozzles with your mouth. A safe procedure in the field is to replace clogged nozzles with new ones and to clean dirty nozzles later when you return to the maintenance yard.

Use a brush and solvent. Wear protective gloves where necessary. **Never** use a metal object to clean tips. Altered spray patterns or flow capacity may result. As a rule of thumb, replace any nozzle that has worn more than 10 percent.

### Hoses and connections

Ensure that connections are tight and that hoses are free from wear. Watch for contact between v-belts and hoses.

Operators of hydraulic spray units face pesticide splash hazards from hose ruptures if high-pressure hoses are not shielded. On compressed-air backpack and hand-held spray units, hose wear is likely to develop at flex points.

Always relieve pressure on a pressurized line before beginning maintenance work. **Never** use hoses that have been removed from a sprayer unit to convey drinking water.

### Tanks and gauges

Check metal parts for deterioration. Many pesticides are corrosive.

Ensure pressure gauges are working and accurate. A sign of malfunction is a shift in reading when operating conditions have not changed.

For backpack units, ensure that both screw-on and pressure-fit caps fit tightly.







---

## Trigger assemblies

Periodically ensure that sealing nuts and hose connections are secure and do not leak.

## Backflow preventers

Periodically have all backflow preventers checked to ensure proper valve seating. Pressure vacuum breakers, double check valves, and reduced pressure devices should be tested annually by trained personnel.

## Equipment cleanup

Clean and decontaminate the equipment after pesticide application and before equipment is stored or repairs are done. This is particularly important before any welding operations are carried out.

Recommended cleaning procedures are as follows:

### For hydraulic sprayers

1. Remove the nozzles and clean them separately.
2. Drain the tank, and clean the suction and line strainers thoroughly before replacing them. (Note: Collection and disposal of any drained materials must be done in accordance with provincial environmental requirements—see [www.env.gov.bc.ca/epd/hazwaste](http://www.env.gov.bc.ca/epd/hazwaste)—and the Occupational Health and Safety Regulation.)
3. Flush the tank of residue.
4. Add soapy water to the tank, and wash the inside of the tank thoroughly. Rinse the pump and flush the entire system, first with the bypass operating, and then with the pressure relief control spring tension completely released. If the spray unit was used to apply a specific family of pesticides, it may be possible to use a specific decontamination solution. For example:
  - **Organophosphates** may be removed with a solution of sodium carbonate (washing soda) and sodium hypochlorite (bleach). Workers must take care when using strong solutions.
  - **Carbamates** may be detoxified using a solution of washing soda or a strong soap solution.
  - **Organochlorines** are generally far more difficult to detoxify than OPs or CBs. Consult with the chemical supplier.

### Note

When flushing sprayers, never discharge the rinse in such a way that it can contaminate water bodies. This can occur, for example, if rinsing water drawn from a dugout is drained onto soil within the catchment area of the dugout.





- 
5. Be sure to decontaminate vehicle tires.
  6. Store roller pumps equipped with nylon rollers in a can of lightweight motor oil. **Do not store a rubber roller pump in oil.**
  7. Clean all nozzles and store in a closed box.
  8. Remove the end caps from wet booms and drain before storing.
  9. Store polyethylene tanks out of the sun.
  10. Flush exterior parts of equipment with water. Use touch-up paint where needed.
  11. Drain all parts to prevent freeze damage. Store sprayer, hoses, and boom in a dry storage area.

#### **For granular applicators**

1. Remove chemical hoppers from the metering unit and clean them.
2. Remove the metering wheel from the housing.
3. Clean the metering opening and shaft.
4. Assemble the components in reverse order.
5. Cover the applicator with a plastic bag to keep it dry, and store it out of the weather.





# Critical parts inspection form

Equipment item (or process area)	INSPECTION INSTRUCTIONS			
Critical part on equipment (or in area)	Conditions to observe	Inspection frequency	Responsibility of	





**INSPECTION RECORD**

Critical part	Date inspected	Next inspection due	Conditions found	Action taken	Supervisor initials





## Equipment calibration

---

Calibrate spray equipment to ensure pesticides are not over-applied. Over-application can create health hazards for fieldworkers. Calibration is simply the adjustment of the machine to make it deliver the right amount of spray for a given area.

Equipment calibration is straightforward. The equipment is operated at the desired pressure and speed over a known area, and the amount of material applied is measured. By a simple ratio, the amount of material that would be applied per hectare (or acre) can be calculated. This information can then be used to adjust pesticide formulations so that the desired amount of active ingredient will be delivered in a given area.

If the strength of the pesticide formulation cannot be adjusted, it may be necessary to alter vehicle speed or the flow rate through the applicator unit to obtain the desired application rate.

A sprayer should be calibrated at the beginning of the spray season and at times throughout the season, depending on nozzle wear. Nozzle wear, a major cause of over-application, is most likely

- With wettable powders
- With high-pressure applications
- With less-durable tips (such as brass)
- At nozzles closest to the pump

If calibration information is not available (for example, if the supplier has gone out of business), you may wish to use the calibration instructions provided in the remainder of this chapter. Instructions cover five major types of application systems:

- Backpack units
- Boom sprayers
- Air-blast sprayers
- Granular applicators
- Aircraft

### Backpack units

1. Mark out an area of 5 metres by 5 metres (25 square metres). The area should have terrain and foliage similar to the area being treated.
2. Fill the sprayer with water, and pump up the sprayer to the desired operating pressure.

#### Note

*The Workers Compensation Act* requires suppliers to provide instructions for the use of equipment, and to ensure supplied equipment is safe when used in accordance with the instructions. It is expected that instructions on how to calibrate pesticide application equipment will be made available to the purchaser. Check with your supplier for information on calibration if you don't already have it.





- 
3. Determine the time needed to spray the area of 25 square metres (walking at the same speed you plan to use in spraying the actual area to be treated).
  4. Either measure the amount of water needed to refill the sprayer, or measure the spray from the nozzle while spraying for the same amount of time it took to cover the test area. Measure the amount of spray in litres or gallons.
  5. Determine the amount applied per hectare or acre using one of the following formulas:
    - Litres per hectare = Litres used in test  $\times$  400
    - Gallons per acre = Gallons used in test  $\times$  160
  6. Make up the formulation so that the active ingredient is applied at the correct rate per hectare or acre. Alternatively, for a given formulation, adjust your walking speed to get the right rate of coverage.

## Boom sprayers

A simple method for calibrating boom sprayers is the **refill method**.

The following description of the refill method is drawn in part from the Agriculture Canada publication *Field Sprayers*.

1. Select nozzles, nozzle arrangement, and operating pressure for desired spray characteristics.
2. To check individual nozzle performance, fill the tank about half full with water. Catch the output of each nozzle for one minute, and measure this water with a measuring cup. Any nozzle tip that delivers more than 10 percent above its rating should be replaced. Special calibration cups are available to help with this procedure. Replace the whole set of tips when measurement indicates appreciable wear.
3. Set out two stakes 200 metres (660 feet) apart in the field.
4. Pick a level spot, and fill the sprayer tank with water. Operate the sprayer to ensure that the supply lines and boom are full before conducting the calibration test. Record the water level on a measuring stick.
5. Spray between the stakes in both directions at a definite speed and pressure. Turn the boom on as you pass the first stake, and turn it off as you pass the last stake in each direction. If the sprayer is not equipped with a low-speed speedometer, record the time required to travel 200 m (660 ft.) while spraying between the stakes. Note the tractor gear used, and mark the throttle setting.





6. Carefully measure the amount of water required to refill the tank to the original mark on the measuring stick. This is the amount needed for spraying a distance of 400 m (1,320 ft.).
7. To calculate the application volume in litres per hectare, use the following formula:

$$\text{Litres per hectare} = \frac{\text{Litres of water added} \times 25}{\text{Boom length (m)}}$$

To calculate the application volume in gallons per acre, use the following formula:

$$\text{Gallons per acre} = \frac{\text{Gallons of water added} \times 33}{\text{Boom length (ft)}}$$

**Note:** Boom length, as used in the formulas above, is not the measured length of the spray boom pipe but the actual width of the spray swath. For single-coverage spraying, the boom length is equal to the number of nozzles times the nozzle spacing.

8. To calculate the speed of travel, use the formulas:

$$\text{Kilometres per hour} = \frac{1,440}{\text{Time (in seconds) to travel 400 m}}$$

or

$$\text{Miles per hour} = \frac{900}{\text{Time (in seconds) to travel 1,320 feet}}$$

9. Make up the pesticide formulation to deliver the amount of active ingredient per hectare or acre at the established speed and pressure. Alternatively, adjust the nozzles, pressure, or speed of travel to produce the correct application rate.

**Note:** If it is not practical or convenient to use calibration stakes 200 m (660 ft.) apart, and a shorter distance is necessary, use the longest possible distance between stakes to obtain an accurate calibration. Calculate the ground speed by using the following formula:

$$\text{Kilometres per hour} = \frac{1,440}{\text{Time (in seconds) to travel 400 m}}$$

or

$$\text{Miles per hour} = \frac{900}{\text{Time (in seconds) to travel 1,320 feet}}$$





Calculate the application volume as follows:

$$\text{Litres per hectare} = \frac{\text{Litres added} \times 25 \times 400}{\text{Boom length (m)} \times \text{Distance travelled (m)}}$$

or

$$\text{Gallons per acre} = \frac{\text{Gallons of water added} \times 33 \times 1,320}{\text{Boom length (ft.)} \times \text{Distance travelled (ft.)}}$$

### Air-blast sprayers

1. Predict the rate of nozzle discharge at the normal operating pressure from information available from the service manual or distributor.
2. Check the actual output per minute of the sprayer by measuring the amount of water discharged from the tank during a timed period of operation.

If the actual output is substantially above the predicted output, nozzle wear may be the problem. If necessary, replace nozzles (and repeat step 2).

3. Establish the desired speed for the tractor and sprayer. If the tractor is not equipped with a low-speed speedometer, determine the number of tree spaces per minute you will pass at the speed you wish to travel using one of the following formulas:

$$\text{Tree spaces per minute} = \frac{\text{km/h desired} \times 16.7}{\text{Tree spacing in metres}}$$

or

$$\text{Tree spaces per minute} = \frac{\text{mph desired} \times 88}{\text{Tree spacing in feet}}$$

For example, you have a tree spacing of 7 metres and you wish to go 2 kilometres per hour.

$$\text{Tree spaces per minute} = \frac{2 \times 16.7}{7} = 4.8 \text{ tree spaces per minute}$$

In the example, your sprayer should cover 4.8 tree spaces in one minute when traveling 2 km/h. Check this by measuring the time needed to travel 4.8 trees. Adjust the speed of the tractor to 4.8 tree spaces per minute, and then mark the throttle and gear settings.







- At the application rate per minute determined in step 2, calculate the amount of liquid sprayed per hectare or acre as follows:

$$\text{Litres/ hectare} = \frac{\text{Sprayer output (litres/minute)} \times 10,000}{\text{Tree spacing (metres)} \times \text{Tree spaces per minute} \times \text{Spray width (normally the distance in metres between rows of trees)}}$$

or

$$\text{Gallons/ acre} = \frac{\text{Sprayer output (gallons/minute)} \times 43,560}{\text{Tree spacing (feet)} \times \text{Tree spaces per minute} \times \text{Spray width (normally the distance in feet between rows of trees)}}$$

- Make up the formulation of active ingredient to obtain the desired amount of active ingredient per hectare or acre at desired vehicle speed and operating pressure.

### Granular applicators

Consult the rate-guide charts in the operator's manual for the proper setting for a desired application. Check the accuracy of a setting using the following procedure:

- Measure and mark 100 metres in the field.
- Fill one hopper with granules.
- Disconnect the delivery tubes from the applicator.
- Catch the material from the applicator in a container such as a bucket or plastic bag while driving the tractor over the 100-metre measured course at the speed that will be used in the actual application.
- Weigh the granules discharged into the container.
- To calculate the square metres of the test area, multiply the row (or band) width in metres times the distance covered (100 metres).
- Calculate the rate per hectare. Multiply the weight collected (from step 5) by 10,000, and divide the answer by the square metres of the test area.

$$\text{Kilograms/hectare} = \frac{10,000 \times \text{kilograms applied over test area}}{\text{Area of measured course in square metres}}$$

- Adjust the applicator if necessary, and repeat steps 4 through 7 until the desired rate is obtained. After one hopper has been correctly adjusted, calibrate the other hoppers by adjusting each one to discharge the same amount of granules over the 100-metre course.





---

## Aircraft application

1. Select desired nozzles, nozzle angle, and operating pressure. Check individual nozzle performance on the landing strip by following step 2 of the **Boom sprayers** section (see pages 197–199). Determine the **flow rate** for the entire system, on the landing strip or in the air, by filling the application tank with a measurable quantity of water, priming the application system, and then noting the time (T) to discharge a volume of water (V). The flow rate is V/T.
2. One method to determine the **effective swath width** for the application is to spread target cards on the ground along a line crosswise to the direction of flight. Conduct a spray run at the desired height and air speed using dyed water. Effective swath width is the distance within which the cards show the proper droplet size and density patterns.
3. Calculate the **application rate** for the desired flying speed as follows:

$$\text{Rate (litres/hectare)} = \frac{\text{Flow rate (litres/minute)} \times 600}{\text{Flying speed (km/h)} \times \text{Swath width (m)}}$$

4. Adjust the formulation concentration, flow rate, or flight speed to provide the correct amount of active ingredient per hectare.





## Emergency telephone numbers

---

### NEAREST HOSPITAL:

---

### FAMILY DOCTOR:

---

### FIRE DEPARTMENT:

---

### POLICE:

---

### OTHER EMERGENCY CONTACTS:

- **WorkSafeBC Prevention Information Line**

Lower Mainland	604 276-3100
Long distance in B.C.	1 888 621-7233
<i>After hours</i>	
Lower Mainland	604 273-7711
Long distance in B.C.	1 866 922-4357
  
- **B.C. Poison Control Centre**

Lower Mainland	604 682-5050
Long distance	1 800 567-8911
  
- **B.C. Provincial Emergency Program**

	1 800 663-3456
--	----------------
  
- **CANUTEC (Canadian Transport  
Emergency Centre)**

	1 613 996-6666
	or *666 (mobile phone)
  
- **CCOHS (Canadian Centre  
for Occupational Health and Safety)**

	1 800 668-4284
--	----------------



## WorkSafeBC Offices

Visit our web site at [WorkSafeBC.com](http://WorkSafeBC.com).

### Abbotsford

2774 Trethewey Street V2T 3R1  
Phone 604 276-3100  
1 800 292-2219  
Fax 604 556-2077

### Burnaby

450 – 6450 Roberts Street V5G 4E1  
Phone 604 276-3100  
1 888 621-7233  
Fax 604 232-5950

### Coquitlam

104 – 3020 Lincoln Avenue V3B 6B4  
Phone 604 276-3100  
1 888 967-5377  
Fax 604 232-1946

### Courtenay

801 30th Street V9N 8G6  
Phone 250 334-8765  
1 800 663-7921  
Fax 250 334-8757

### Kamloops

321 Battle Street V2C 6P1  
Phone 250 371-6003  
1 800 663-3935  
Fax 250 371-6031

### Kelowna

110 – 2045 Enterprise Way V1Y 9T5  
Phone 250 717-4313  
1 888 922-4466  
Fax 250 717-4380

### Nanaimo

4980 Wills Road V9T 6C6  
Phone 250 751-8040  
1 800 663-7382  
Fax 250 751-8046

### Nelson

524 Kootenay Street V1L 6B4  
Phone 250 352-2824  
1 800 663-4962  
Fax 250 352-1816

### North Vancouver

400 – 224 Esplanade Ave. W. V7M 1A4  
Phone 604 276-3100  
1 888 875-6999  
Fax 604 232-1558

### Prince George

1066 Vancouver Street V2L 5M4  
Phone 250 561-3700  
1 800 663-6623  
Fax 250 561-3710

### Surrey

100 – 5500 152 Street V3S 5J9  
Phone 604 276-3100  
1 888 621-7233  
Fax 604 232-7077

### Terrace

4450 Lakelse Avenue V8G 1P2  
Phone 250 615-6605  
1 800 663-3871  
Fax 250 615-6633

### Victoria

4514 Chatterton Way V8X 5H2  
Phone 250 881-3418  
1 800 663-7593  
Fax 250 881-3482

### Head Office / Richmond

*Prevention Information Line:*  
Phone 604 276-3100  
1 888 621-7233 (621-SAFE)

#### *Administration:*

6951 Westminster Highway  
Phone 604 273-2266  
*Mailing Address:*  
PO Box 5350 Stn Terminal  
Vancouver BC V6B 5L5

### After Hours

**Health & Safety Emergency**  
604 273-7711  
1 866 922-4357 (WCB-HELP)

R06/06

